

Tubular motor:

**GEIGER SOL.TECl ine**

Motor control:

**SOL.TECl ine ZIP-Perfection (GB45...-E11)**

for screens with ZIP guidance



EN

**Original assembly and  
operating instructions**

EN

## Index

1. General information .....	2
2. Guarantee .....	2
3. Intended use .....	3
4. Safety instructions .....	3
5. Safety instructions for assembly .....	4
6. Installation instructions .....	5
7. Information for the specialist electrician .....	6
8. Connection of the setting switch .....	6
9. Factory settings (note to OEM).....	7
10. Automatic setting of the end positions (note to installer).....	7
11. Manual programming of the end positions (note to installer).....	7
12. Semi-automatic programming of the end positions (note to installer).....	8
13. Exit the programming modes .....	8
14. Starting the setting mode.....	8
15. Change/delete the end position .....	8
16. Obstacle detection .....	9
17. Referencing / End position correction .....	10
18. Resetting to factory setting .....	10
19. What to do if.....	10
20. Maintenance .....	10
21. Declaration of conformity .....	11
22. Technical data for SOL.TECl ine motors.....	12
23. Notes on waste disposal .....	12

EN

## 1. General information

Dear customer,

By purchasing a GEIGER motor you have decided on a quality product from GEIGER.

Thank you very much for your decision and the confidence placed in us.

Before you put this drive into operation please observe the following safety instructions. It serves for the prevention of danger and for the avoidance of personal injury and damage to property.

The installation and operating instructions contain important information for the installer, the specialist electrician and the user. Please pass on these instructions if you transfer the product. These instructions should be kept by the user.

## 2. Guarantee

In the case of incorrect installation contrary to the installation and operating instructions and/or constructional modification, the legal and contractual guarantee for property damage and product liability lapses.

### 3. Intended use

The motors of the series **SOL.TEcline (GB45...-E11)** with electronic end stop are designed exclusively for the operation of ZIP screens.

The motors may not be used for the operation of roller grilles, garage doors, furniture and lifting tools.

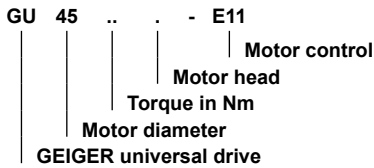

### 4. Safety instructions



**ATTENTION: Important safety instructions. For personal safety, it is important to follow these instructions. Please keep these instructions for future reference.**

- ▶ Do not allow children to play with stationary controls. Keep remote controls away from children.
- ▶ The installation is to be checked regularly for defective balance, signs of wear or damaged cables and springs, if relevant.
- ▶ Do observe the moving sun protection system and keep persons away until it has closed completely.
- ▶ When operating the manual release with the sun protection system open, please be cautious as it can fall down quickly if springs or tapes wear off or are broken.
- ▶ Do not operate the device if operations such as, for example, window cleaning are to be carried out in the vicinity.
- ▶ Disconnect the automatic controlled device from the mains power supply if operations such as, for example, window cleaning are being carried out in the vicinity.
- ▶ During operation observe the danger zone.
- ▶ Do not use the installation if people or objects are in the danger zone.
- ▶ Urgently shut down damaged installations until repair.
- ▶ Unconditionally shut down the unit during maintenance and cleaning operations.
- ▶ Pinching and shearing points are to be avoided and must be secured.
- ▶ This appliance can be used by children aged 8 and above and persons whose physical, sensorial or mental capacities are impaired, or who have no experience or know-how if they have been supervised or been given instructions on the use of the appliance and if they understand the possible resulting dangers. Children are not permitted to play with the device. Cleaning and maintenance should not be carried out by children.
- ▶ The rated sound pressure level is less than 70 dB(A).
- ▶ Disconnect the device from the mains power supply for maintenance and replacement of parts.  
If the motor is disconnected via a plug connection the operator must be able to control - from any place to which it has access – that the plug is removed.  
If this is not possible - due to design or installation - the disconnection from the power supply must be ensured via locking in the disconnected position (e.g. isolator).
- ▶ The motor tube can get very hot during prolonged use.  
When working on the unit, do not touch the tube before it has cooled down.

EN

## 5. Safety instructions for assembly



**ATTENTION: Important safety instructions. Follow all installation instructions, as incorrect installation can lead to serious injuries.**

- ▶ When mounting the motor without any mechanical protection of the driven parts and of the tube which may become hot, the motor must be installed at a height of at least 2.5 m above the ground or of another level which provides access to the drive.
- ▶ Before the motor is installed, all cables which are not needed are to be removed and all equipment which is not needed for power-operated actuation is to be put out of operation.
- ▶ The actuating element of a manual release must be mounted at a height of less than 1.8 m.
- ▶ If the motor is controlled by a switch or pushbutton, the switch or pushbutton must be mounted within eyeshot of the motor. The switch or pushbutton must not be located in the vicinity of moving parts. The height of installation must be at least 1.5 m above the floor.
- ▶ Permanently installed control devices must be attached visibly.
- ▶ In case of devices extending horizontally, a horizontal distance of at least 0.4 m must be respected between the fully extended part and any other fixed element.
- ▶ The rated speed and the rated torque of the motor must be compatible with the device.
- ▶ The mounting accessories that are used must be designed in accordance with the selected rated torque.
- ▶ Good technical knowledge and good mechanical skills are necessary for the motor installation. Incorrect installation can lead to serious injury. Electrical work must be carried out by a qualified electrician in accordance with the regulations in force locally.
- ▶ Only use connecting cables that are suitable with the environmental conditions and which meet the construction requirements. (see accessories catalogue)
- ▶ If the device is not equipped with a connecting cable and a plug, or other means for disconnecting from the mains with a contact opening on each pole according to the conditions of the overvoltage category III for full disconnection, a disconnecting device of this type must be incorporated into the permanently installed electrical installation according to the wiring rules.
- ▶ Do not mount the connecting cables near hot surfaces.
- ▶ A plug for the disconnection of the motor from the power supply must be accessible after installation.
- ▶ Damaged connecting cables must be replaced by GEIGER connecting cables of the same type.
- ▶ The device must be mounted as described in the installation instructions. Fixations shall not be made with adhesives since they are regarded as unreliable.

## 6. Installation instructions



**Before fixing, the strength of the masonry or of the subsurface is to be checked.**

### Installation of the ZIP system

To ensure proper operation of the system, the box and the guide rails must be installed accurately.

Check the right-angled installation and measure the horizontal distances of the guide rails and the length of the two diagonals.

$D1 = D2 (\pm 2 \text{ mm})$

$D3 = D4 = D5$

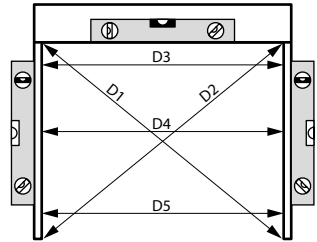

### Installation of the drive



**Prior to installation please check to ensure there is no visible damage to the motor like cracks or open cables.**



**Caution: If the tube is screwed/riveted to the drive, the measure must be taken from the tube end to the center of the drive and marked on the tube.**

When drilling the winding shaft **never** drill into the area of the tubular motor!

When inserting into the shaft, the tubular motor must **not** be struck and must **not** be allowed to fall into the shaft.

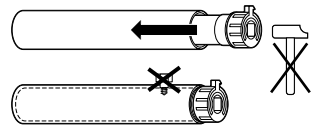

### Installation into the screen:

Insert motor with a suitable adapter and drive into the shaft up to the stop of the shaft adapter.

Fix the motor support on the side piece.

Fix the motor together with the shaft on the motor support.

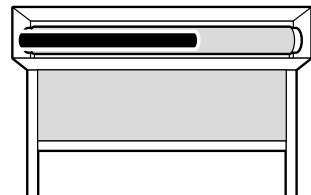

### Depending on the selected motor head, different fixation systems can be used:

- Place the motor with square insert in the star-shaped bearer and lock with pin
- Place the motor into the existing engine bearer and lock
- Place the motor in a compatible engine bearer with clip system and lock with spring or rotating lever



**The GEIGER SOL.TECl ine motor is suitable for shaft diameters from 50 mm!**

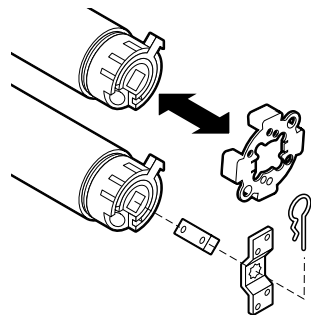

EN

## 7. Information for the specialist electrician



**Caution: Important installation instructions. Please follow all instructions since incorrect installation can lead to the destruction of the motor and the switching unit.**

The operations with the service clamps may be accomplished only by an electrical specialist.

Motors with electronic limit stops can be connected in parallel. In this case the maximum load of the switching unit must not be exceeded.

When changing the running direction the switchover must be effected through an off-position.

When changing the running direction the switchover time must be at least 0.5 s.

With a three-phase network, please use the same external conductor in order to control the UP and DOWN directions. PVC cables are not suitable for equipment used outdoors or exposed to prolonged high levels of UV radiation. These cables should not be used if they are likely to touch metal parts that can heat up to temperatures exceeding 70°C. Connecting cables with plug connectors of the Hirschmann Company are tested and approved with couplings of the Hirschmann Company.

In order to prevent a malfunction caused by coupling, the supply line (ref. NYM) from the actuator/switch to the motor must not exceed 100 m in case of motors with electronic end stops.

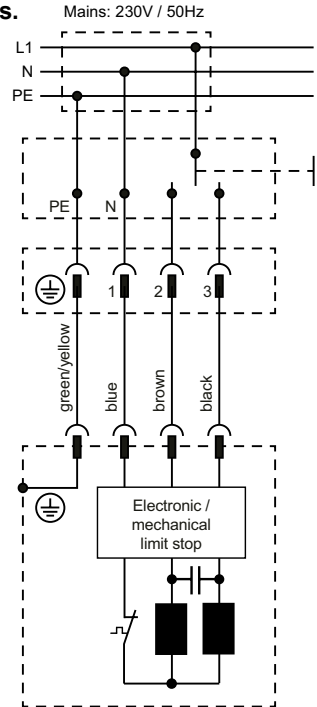

## 8. Connection of the setting switch



**In order to set the end positions on SOL.TECLine motors, any setting switch can be used that has a programming key or that allows a simultaneous UP/DOWN command. In this case, the UP/DOWN keys must be activated simultaneously instead of the programming key.**

EN

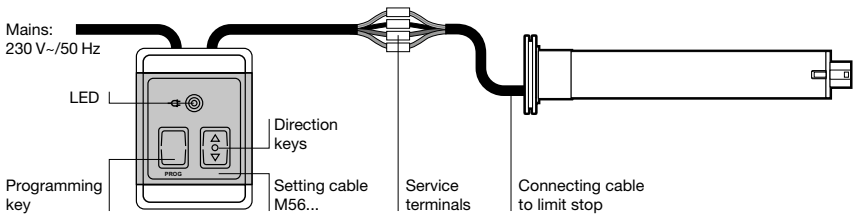

Connect setting cable to the connecting cable of the motor (see diagram on the back of the setting switch). The assignment to the direction of rotation is dependent on the installation situation of the drive. Then connect the setting switch to the 230V mains.

Article Number / GEIGER setting switch	
<b>M56F152</b>	with service terminal (D), 5 wires, SMI compatible
<b>M56F153</b>	with service terminal (CH), 5 wires, SMI compatible
<b>M56F154</b>	with service terminal (D), 4 wires

## 9. Factory settings (note to OEM)

The drive is delivered with the factory settings which allow any number of UP and DOWN runs with max. power.

**This mode is optimally suited for initial commissioning in the factory.**

**Note: GEIGER recommends to activate the learning mode of the drive already in the factory.**

## 10. Automatic setting of the end positions (note to installer)

**Note: Automatic setting cannot be used with 30 Nm motors.**



**The drive must run continuously for at least 3 seconds before an end position can be taught in to the torque.**

### Programming the end positions

1. To activate the programming mode, press the PROG key or the UP and DOWN keys at the same time until the motor confirms (1 x „clac-clac“). The learning mode is indicated with each move command by a short interruption of the screen movement (start-stop-start).
2. Keep the UP or DOWN key pressed to move the screen to the desired end position until the motor reaches the stop and switches off (torque shutoff).
3. Keep the UP or DOWN key presses to move the screen in the opposite direction until the motor reaches the stop and switches off (torque shutoff).
4. Repeat steps 2. & 3.
5. The programming process is then completed.



**The direction of rotation of the motor is automatically assigned to the upper and lower end positions.**

6. After learning the end positions, the obstacle detection must be fine-tuned. For this purpose a complete uninterrupted travel from UP to DOWN as well as from DOWN to UP must be carried out. The sequence is irrelevant. The drive then changes to normal operation and the obstacle detection is active.

## 11. Manual programming of the end positions (note to installer)



**The distance between the upper and lower end positions must be at least 1/4 shaft rotation (approx. 7 cm). If the distance is not maintained, the drive deletes the end positions that have already been stored and starts the programming procedure all over again.**

### Programming the end positions

1. To activate the programming mode, press the PROG key or the UP and DOWN keys simultaneously until the motor confirms (1 x „clac-clac“). The learning mode is indicated with each move command by a short interruption of the screen movement (start-stop-start).
2. Press and hold the UP or DOWN key to move the screen to the desired end stop until the desired position is reached.
3. The position is saved by pressing the PROG key for at least 1 sec. The drive signals that the first end position has been saved (2 x „clac-clac“).
4. Press and hold the UP or DOWN key to move the screen in the opposite direction until the desired position is reached.
5. The position is saved by pressing the PROG key for at least 1 second. The drive signals that the second end position has been saved (3 x „clac-clac“).
6. The learning process is then completed.
7. After learning the end positions, the obstacle detection must be fine-tuned. For this purpose a complete uninterrupted travel from UP to DOWN as well as from DOWN to UP must be carried out. The sequence is irrelevant. The drive then changes to normal operation and the obstacle detection is active.

## 12. Semi-automatic programming of the end positions (note to installer)

**Note:** Semi-automatic setting cannot be used with 30 Nm motors.



The drive must run for at least 3 seconds without interruption before an end position can be taught.

### Programming the end positions

1. To activate the programming mode, press the PROG key or the UP and DOWN keys simultaneously until the motor confirms (1 x „clack-clack“). The learning mode is indicated with each move command by a short interruption of the screen movement (start-stop-start).
2. Keep the UP or DOWN key pressed to move the screen to the desired end position until the motor reaches the stop and switches off (torque shutoff).
3. Press and hold the UP or DOWN key to move the screen in the opposite direction until the desired position is reached.
4. The position is saved by pressing the PROG key for at least 1 second. The drive signals that the end position has been saved (2 x „clack-clack“).
5. Repeat step 2.
6. The learning process is then completed.-
7. After learning the end positions, the obstacle detection must be fine-tuned. For this purpose a complete uninterrupted travel from UP to DOWN as well as from DOWN to UP must be carried out. The sequence is irrelevant. The drive then changes to normal operation and the obstacle detection is active.

## 13. Exit the programming modes

The learning process can be cancelled completely at any time by pressing the PROG key for 20 to 30 sec. The drive signals the termination by 4x UP/DOWN movements.

The drive returns to the delivery state.

## 14. Starting the setting mode

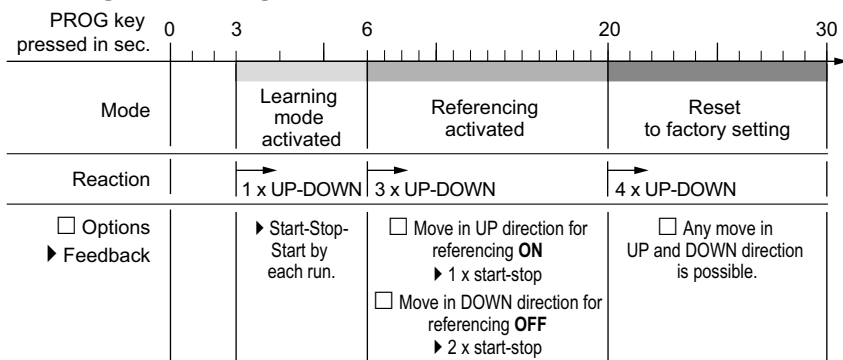

As soon as the drive has entered the respective mode and has started to respond, the PROG key can be released and the appropriate setting can be made.

## 15. Change/delete the end position

In order to change or delete the end positions, a new programming must be started (see «Setting of the end stops»).

## 16. Obstacle detection

The drive has a sensitive obstacle detection in the DOWN direction as well as a blockage detection in the UP direction. The required torque is automatically readjusted at any time. Slow changes in the system due to ageing, dirt, cold or heat are thus automatically taken into account. If a travel command is blocked by an obstacle, the motor switches off and a short return run takes place. The motor tries up to three times to reach the end position. If an obstacle is still detected, the drive returns to the corresponding end position.

Drives up to 20 Nm torque also have a sensitive obstacle detection immediately after the upper end position in the DOWN direction. This function is not available with the 30 Nm power level.



**Because of the motor sensitive obstacle detection, the correct dimensioning of the torque for the respective installation size is essential.**

**Note: the chart below serves only as indication to determine the motor size.**

Whether the specified motor size is sufficient for the respective installation size and is sensitive enough should be examined with the previously unknown factors like weight of the sun protection (total weight), friction, etc. for each installation type and size, as there might be important variations.

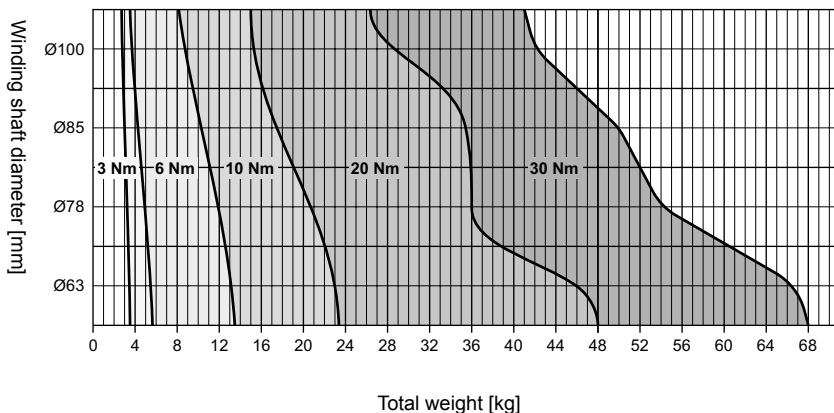

## 17. Referencing / End position correction

If, e.g. due to temperature changes, a **screen elongation/shortening** has occurred, this is automatically corrected when the screen is closed, depending on the setting.

If, due to changes in temperature, the **winding behaviour** should change and the screen should run against the stop, an immediate end position correction or a torque shut-off takes place, depending on the setting.

After the first reference run, the motor automatically detects the torque required to close the screen and closes it with the lowest possible force in order to optimally protect the fabric.

## 18. Resetting to factory setting

To reset the drive to the factory setting, press the PROG key for 20 to 30 sec. The drive signals the reset with 4 UP/DOWN movements.

The drive returns to the delivery state.

## 19. What to do if...

Problem	Solution
<b>Motor does not run.</b>	<ul style="list-style-type: none"><li>• Motor not plugged in. Please check the plug connection.</li><li>• Check connecting cable for possible damage.</li><li>• Check the mains voltage and allow the cause of the voltage breakdown to be tested by a specialist electrician.</li></ul>
<b>Instead of in the upwards direction, motor runs downwards.</b>	<ul style="list-style-type: none"><li>• The control leads are interchanged. Exchange black/brown control leads.</li></ul>
<b>Motor only runs in one direction.</b>	<ul style="list-style-type: none"><li>• Motor in the end position. Run motor in the opposite direction. Re-adjust the end positions, if necessary.</li></ul>
<b>After running several times, the motor breaks down and no longer responds.</b>	<ul style="list-style-type: none"><li>• The motor became too hot and has switched off. Try it again after a cooling time of about 15 min.</li></ul>

## EN 20. Maintenance

The drive is maintenance-free.

# 21. Declaration of conformity



## EU Declaration of Conformity

Gerhard Geiger GmbH & Co. KG  
Antriebstechnik  
Schleifmühle 6  
D-74321 Bietigheim-Bissingen

**Product designation:**

Venetian blinds motor, motor for rolling shutters, motor for awnings

**Type designation:**

GJ56.., GR45.., GU45.., GSI56.., GB35.., GB45.., GB59..

**Applied directives:**

2006/42/EG  
2014/53/EU  
2011/65/EU+(EU)2015/863+(EU)2017/2102  
(EU)2023/826

**Applied standards:**

EN 60335-1:2012  
EN 60335-1:2012/AC:2014  
EN 60335-1:2012/A11:2014  
EN 60335-1:2012/A13:2017  
EN 60335-1:2012/A1:2019  
EN 60335-1:2012/A14:2019  
EN 60335-1:2012/A2:2019  
EN 60335-1:2012/A15:2021  
EN 60335-1:2012/A16:2023  
  
EN 60335-2-97:2006+A11:2008+A2:2010+A12:2015  
EN 62233:2008+Ber.1:2008+Cor.:2008  
  
EN IEC 55014-1:2021  
EN IEC 55014-2:2021  
EN IEC 61000-3-2:2019+EN IEC 61000-3-2:2019/A1:2021  
EN 61000-3-3:2013+EN 61000-3-3:2013/A1:2019+EN 61000-3-3:2013/A2:2022  
  
ETSI EN 301 489-1 V2.2.3 (2019-11)  
ETSI EN 301 489-3 V2.1.1(2019-03)  
ETSI EN 300 220-2 V3.2.1 (2018-06)

**Authorized representative for technical data:**

Gerhard Geiger GmbH & Co. KG

**Address:**

Schleifmühle 6, D-74321 Bietigheim-Bissingen

Bietigheim-Bissingen, 19.05.2025

  
Roland Kraus (General Manager)

100W1518 rev.0525

Gerhard Geiger GmbH & Co. KG  
Schleifmühle 6 | D-74321 Bietigheim-Bissingen  
Phone +49 (0) 7142 9380 | Fax +49 (0) 7142 938 230 | info@geiger.de | www.geiger.de  
Sitz Bietigheim-Bissingen | Amtsgericht Stuttgart HRB. 300591 | USt-IdNr. DE145002146  
Komplementär: Geiger Verwaltungs-GmbH | Sitz Bietigheim-Bissingen | Amtsgericht Stuttgart HRB 300481  
Geschäftsführer: Roland Kraus, Dr. Bertram Melzig-Thiel | WEEE-Reg.-Nr. DE47902323

EN

Current declarations of conformity are available under [www.geiger.de](http://www.geiger.de)

## 22. Technical data for SOL.TECl ine motors

Technical data of tubular motor SOL.TECl ine-SOC (GB45..)					
	GB4503	GB4506	GB4510	GB4520	GB4530
<b>Voltage</b>	230 V~/50 Hz				
<b>Current</b>	0,35 A	0,36 A	0,47 A	0,63 A	0,80 A
<b>Cos Phi (cos<math>\varphi</math>)</b>	>0,95				
<b>Inrush current (factor)</b>	x 1,2				
<b>Power</b>	80 W	83 W	105 W	140 W	180 W
<b>Torque</b>	3 Nm	6 Nm	10 Nm	20 Nm	30 Nm
<b>Speed</b>	26 rpm	15 rpm	15 rpm	15 rpm	15 rpm
<b>Protection class</b>	IP 44				
<b>Total length<sup>1)</sup></b>	467,5 mm	466,0 mm	476,0 mm	506,0 mm	526,0 mm
<b>Operating mode</b>	S2 4 min	S2 4 min	S2 4 min	S2 4 min	S2 4 min
<b>Sound pressure level<sup>2)</sup></b>	39 dB(A)	39 dB(A)	39 dB(A)	39 dB(A)	39 dB(A)
<b>Diameter</b>	45 mm				
<b>Weight</b>	ca. 1,70 kg	ca. 1,85 kg	ca. 1,90 kg	ca. 2,00 kg	ca. 2,20 kg
<b>Air humidity</b>	dry and non-condensing place				
<b>Storage temperature</b>	T = -15°C .. +70°C				

<sup>1)</sup> SOL.TECl ine-ROC: + 5,9 mm / SOL.TECl ine-COM: + 4,2 mm

<sup>2)</sup> The average sound pressure level data are intended for guidance only. The values were determined by GEIGER at a distance of 1 m, with a hanging motor at idle speed and averaged over 10 seconds. There is no reference to any specific test standard.

Subject to technical modifications. Please find information to the ambient temperature range of our GEIGER motors under [www.geiger.dee](http://www.geiger.dee)

## 23. Notes on waste disposal

### Recycling of packaging materials

In the interest of environmental protection, please contact your local government's recycling or solid waste management department to learn more about the services it provides.

### Waste disposal of electric and electronic equipment

Electrical and electronic equipment must be collected and disposed of separately in accordance with EU regulations.

EN

For technical questions, please call our service team at: **+49 (0) 7142 938 333**. They will be happy to assist you.

**GEIGER**  
ANTRIEBSTECHNIK

Gerhard Geiger GmbH & Co. KG  
Schleifmühle 6 | D-74321 Bietigheim-Bissingen  
T +49 (0) 7142 9380 | F +49 (0) 7142 938 230  
[info@geiger.de](mailto:info@geiger.de) | [www.geiger.de](http://www.geiger.de)

