

GEIGER

ANTRIEBSTECHNIK

Tubular motor:

GEIGER SOLIDline

Motor control:

SOLIDline X01 Radio (GU45...-F12)

for rolling shutters with stoppers and anti-lift device

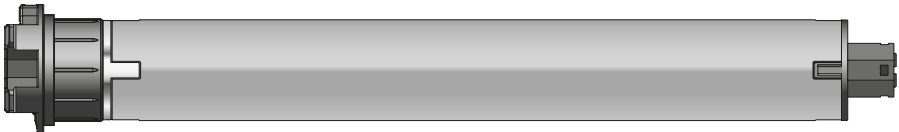

EN

**Original assembly and
operating instructions**

EN

Index

1. Special features of the SOLIDline X01 Radio	3
2. General information	4
3. Guarantee	4
4. Intended use	4
5. Safety instructions	5
6. Safety instructions for assembly	6
7. Installation instructions	7
8. Information for the specialist electrician	8
9. Setting the end positions	9
10. Retrain end positions (wired)	9
11. Switching to Radio Operation	10
12. Initial commissioning	10
13. Changing an End Position in Radio Mode	11
14. Additional Functions	11
15. Obstacle recognition	13
16. End position correction	13
17. Resetting to factory setting	13
18. What to do if	14
19. Maintenance	14
20. Declaration of conformity	15
21. Technical data	16
22. Notes on waste disposal	16

1. Special features of the SOLIDline X01 Radio

Application range: rolling shutter systems

Precondition: anti-lift device and stoppers

Initial operation with Plug & Play

- Only one operation to the upper and the lower end stop is required.
Ready! Plug & Play!

Cloth protection with the Soft-System

- The GEIGER soft position ensures that the hanging stops a few millimetres before reaching the end position. The hanging is thus optimally protected. Two exceptions: the programming runs and the reference runs after 50 cycles.
- During the programming or the reference runs the GEIGER motor control ensures a „soft shutdown“ when reaching the end positions. Hanging and the rolling shutter system - compared to conventional torque motors – are well preserved.

Synchronous position in the upper end position

- The **SOLIDline X01 Radio** ensures that the bottom lath in the upper end position is always the same distance away from the upper end rail.
- When rolling shutters of different sizes are mounted next to each other, the bottom laths are positioned on the same level. This is a really nice visual upgrade for the house façade: **the GEIGER synchronous position.**

Obstacle detection

- Protection of the rolling shutter system during retraction

Antifreeze protection

- The situation «hanging frozen to the window sill», is recognized by the system and the curtain will not be damaged.

EN

2. General information

Dear customer,

By purchasing a GEIGER motor you have decided on a quality product from GEIGER.

Thank you very much for your decision and the confidence placed in us.

Before you put this drive into operation please observe the following safety instructions. It serves for the prevention of danger and for the avoidance of personal injury and damage to property.

The installation and operating instructions contain important information for the installer, the specialist electrician and the user. Please pass on these instructions if you transfer the product. These instructions should be kept by the user.

3. Guarantee

In the case of incorrect installation contrary to the installation and operating instructions and/or constructional modification, the legal and contractual guarantee for property damage and product liability lapses.

4. Intended use

The tubular motors of the model range **SOLIDline (GU45...-F12)** are designed for the operation of rolling shutters with anti-lift device and stoppers

The motors may not be used for the operation of roller grilles, garage doors, furniture and lifting tools.

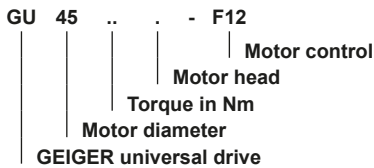

5. Safety instructions



ATTENTION: Important safety instructions. For personal safety, it is important to follow these instructions. Please keep these instructions for future reference.

- ▶ Do not allow children to play with stationary controls. Keep remote controls away from children.
- ▶ The installation is to be checked regularly for defective balance, signs of wear or damaged cables and springs, if relevant.
- ▶ Do observe the moving sun protection system and keep persons away until it has closed completely.
- ▶ When operating the manual release with the sun protection system open, please be cautious as it can fall down quickly if springs or tapes wear off or are broken.
- ▶ Do not operate the device if operations such as, for example, window cleaning are to be carried out in the vicinity.
- ▶ Disconnect the automatic controlled device from the mains power supply if operations such as, for example, window cleaning are being carried out in the vicinity.
- ▶ During operation observe the danger zone.
- ▶ Do not use the installation if people or objects are in the danger zone.
- ▶ Urgently shut down damaged installations until repair.
- ▶ Unconditionally shut down the unit during maintenance and cleaning operations.
- ▶ Pinching and shearing points are to be avoided and must be secured.
- ▶ This appliance can be used by children aged 8 and above and persons whose physical, sensorial or mental capacities are impaired, or who have no experience or know-how if they have been supervised or been given instructions on the use of the appliance and if they understand the possible resulting dangers. Children are not permitted to play with the device. Cleaning and maintenance should not be carried out by children.
- ▶ The rated sound pressure level is less than 70 dB(A).
- ▶ Disconnect the device from the mains power supply for maintenance and replacement of parts.
If the motor is disconnected via a plug connection the operator must be able to control - from any place to which it has access – that the plug is removed.
If this is not possible - due to design or installation - the disconnection from the power supply must be ensured via locking in the disconnected position (e.g. isolator).
- ▶ The motor tube can get very hot during prolonged use.
When working on the unit, do not touch the tube before it has cooled down.

EN

6. Safety instructions for assembly



ATTENTION: Important safety instructions. Follow all installation instructions, as incorrect installation can lead to serious injuries.

- ▶ When mounting the motor without any mechanical protection of the driven parts and of the tube which may become hot, the motor must be installed at a height of at least 2.5 m above the ground or of another level which provides access to the drive.
- ▶ Before the motor is installed, all cables which are not needed are to be removed and all equipment which is not needed for power-operated actuation is to be put out of operation.
- ▶ The actuating element of a manual release must be mounted at a height of less than 1.8 m.
- ▶ If the motor is controlled by a switch or pushbutton, the switch or pushbutton must be mounted within eyeshot of the motor. The switch or pushbutton must not be located in the vicinity of moving parts. The height of installation must be at least 1.5 m above the floor.
- ▶ Permanently installed control devices must be attached visibly.
- ▶ In case of devices extending horizontally, a horizontal distance of at least 0.4 m must be respected between the fully extended part and any other fixed element.
- ▶ The rated speed and the rated torque of the motor must be compatible with the device.
- ▶ The mounting accessories that are used must be designed in accordance with the selected rated torque.
- ▶ Good technical knowledge and good mechanical skills are necessary for the motor installation. Incorrect installation can lead to serious injury. Electrical work must be carried out by a qualified electrician in accordance with the regulations in force locally.
- ▶ Only use connecting cables that are suitable with the environmental conditions and which meet the construction requirements. (see accessories catalogue)
- ▶ If the device is not equipped with a connecting cable and a plug, or other means for disconnecting from the mains with a contact opening on each pole according to the conditions of the overvoltage category III for full disconnection, a disconnecting device of this type must be incorporated into the permanently installed electrical installation according to the wiring rules.
- ▶ Do not mount the connecting cables near hot surfaces.
- ▶ A plug for the disconnection of the motor from the power supply must be accessible after installation.
- ▶ Damaged connecting cables must be replaced by GEIGER connecting cables of the same type.
- ▶ The device must be mounted as described in the installation instructions. Fixations shall not be made with adhesives since they are regarded as unreliable.

EN

7. Installation instructions



Before fixing, the strength of the masonry or of the subsurface is to be checked.



Prior to installation please check to ensure there is no visible damage to the motor like cracks or open cables.



Caution: If the tube is screwed/riveted to the drive, the measure must be taken from the tube end to the center of the drive and marked on the tube.

When drilling the winding shaft never drill into the area of the tubular motor!

When inserting into the shaft, the tubular motor must not be struck and must not be allowed to fall into the shaft.

Installation into the rolling shutter:

Fix motor support to available stud bolts or in the side frame.

Insert motor into the shaft with a suitable adapter and drive up to the stop of the shaft adapter.

Insert roller capsule on the opposite side.

Put shaft with motor on motor support or on pivoting engine bearer. On the opposite side pull out roller capsule until bolt fits into ball bearing.

Screw together roller capsule with shaft.

Screw together shaft with tubular carrier.

Fix rolling shutter casing to shaft.

Alternative: Use fixation plates for front box units. Attach the motor. The bearing locks into place. To loosen, turn the spring washer.



In order to adjust the end positions, a rolling shutter system with upper end stop and anti-lift device is required.



The GEIGER SOLIDline motor is suitable for shaft diameters from 50 mm!

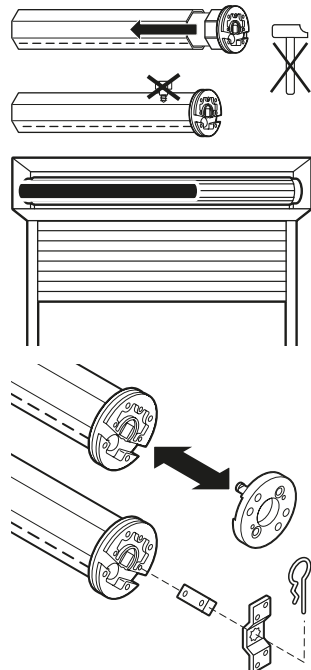

EN

8. Information for the specialist electrician



Caution: Important installation instructions.
Please follow all instructions since incorrect installation can lead to the destruction of the motor and the switching unit.

The operations with the service clamps may be accomplished only by an electrical specialist. Motors with electronic limit stops can be connected in parallel. In this case the maximum load of the switching unit must not be exceeded.

When changing the running direction the switchover must be effected through an off-position.

When changing the running direction the switchover time must be at least 0.5 s.

With a three-phase network, please use the same external conductor in order to control the UP and DOWN directions.

PVC cables are not suitable for equipment used outdoors or exposed to prolonged high levels of UV radiation. These cables should not be used if they are likely to touch metal parts that can heat up to temperatures exceeding 70°C.

Connecting cables with plug connectors of the Hirschmann Company are tested and approved with couplings of the Hirschmann Company.

In order to prevent a malfunction caused by coupling, the supply line (ref. NYM) from the actuator/switch to the motor must not exceed 100m in case of motors with electronic end stops.

Connection diagram cable mode

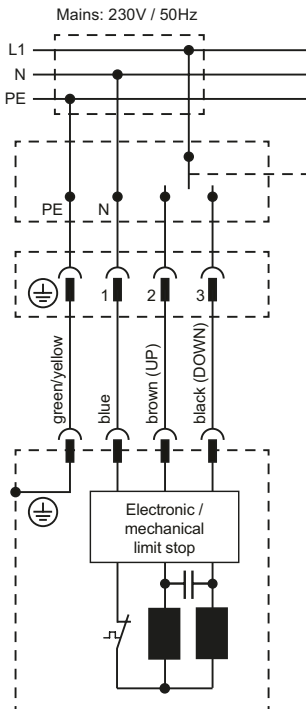

Connection diagram for radio mode

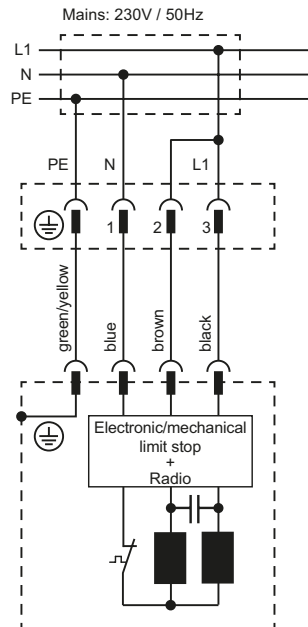

EN

9. Setting the end positions

IMPORTANT: The drive is in wired mode when delivered from the factory. If the drive is switched from switch mode to radio mode before the learning mode is complete, the standard learning process will continue.

1. Connect the drive's connection cable to the control cable.
2. Move to both end positions using the switch or radio control. The order is arbitrary. The drive allows four torque cut-offs per end position. The respective end position is only learned after the fifth torque cut-off.
3. DONE!

10. Retrain end positions (wired)

IMPORTANT: Both end positions are relearned for torque. The fifth shutdown in each case determines the end positions.

1. Move the curtain to any position of your choice.



Please note: respect a distance of approximately 50 cm from the end positions

2. Operate as follows:

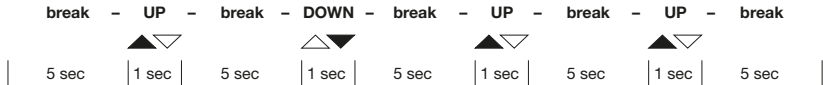

Please note: a break of at least 5 seconds must be respected between the different runs.

3. DONE!

11. Switching to Radio Operation

4. The factory default setting of the drive is wired operation.
5. The end positions must be set before switching to radio operation.
6. The drive will only accept radio signals once it has been powered for at least 30 seconds via terminals 2 (brown) and 3 (black) (see "Radio Mode Wiring Diagram" in Chapter 8).
7. After 20 seconds, the drive responds with 4× "click-click." The power supply must remain connected. After the full 30 seconds of dual powering, the drive automatically switches to radio mode and will permanently remain in this mode, even after a power interruption.
8. Radio mode can only be exited by changing the wiring (see the "wired" wiring diagram in Chapter 8), disconnecting power for at least 3 seconds, and performing at least one operation via a switch.
9. Actions that exclusively concern radio operation can be found in Chapters 12 to 14 or in the operating instructions of the radio components. The drive confirms the radio components' acknowledgements with a single up/down movement (1× "click-click").
10. A brief press of the Up or Down button sets the drive into continuous movement toward its set end position. The movement can be stopped by pressing the Stop button or the button for the opposite direction.

12. Initial commissioning

Teaching-in the first transmitter

1. Connect the drive to the power supply. The drive clicks (short UP and DOWN movement) and starts in teach-in mode.

For multi-channel hand-held transmitters: Select the desired channel.

2. Press the UP and DOWN keys on the hand-held transmitter simultaneously until the drive clicks. The hand-held transmitter and the drive are connected to each other.

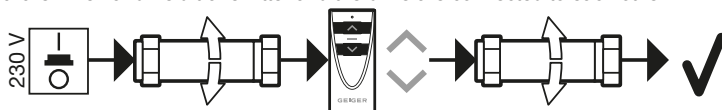

Changing the rotation direction of the drive

1. Press the PAIR key for at least 5 seconds. The drive clicks.
2. Press the STOP key for at least 2 seconds. The drive clicks, the direction of rotation of the drive has been changed.

Teaching-in another hand-held transmitter

1. Press the PAIR key for at least 5 seconds on the hand-held transmitter that has already been programmed. The drive clicks.
2. Press the PAIR key on the new hand-held transmitter for at least 2 seconds. The drive clicks, the new hand-held transmitter has been programmed.

13. Changing an End Position in Radio Mode

End positions can be manually adjusted in radio mode. For this, a specific button sequence on the hand-held or wall transmitter is required. After the sequence, one end position can be adjusted at a time.

1. The drive must be in motion for the end-position learning mode to be activated.
2. Then enter this sequence continuously:

STOP	Break	STOP	Break	STOP	Break	UP+DOWN	Break	STOP
—		—		—		▲▼		—
1 Sec.	0,5 Sec.	1 Sec.	0,5 Sec.	1 Sec.	0,5 Sec.	2 Sec.	0,5 Sec.	1 Sec.

3. Move the drive in the direction of the desired end position. The drive briefly interrupts movement to indicate that it is now in learning mode.
4. The direction in which the drive moves after this brief interruption determines which end position will be programmed (UP = upper end position, DOWN = lower end position).
5. Once the desired end position is reached, stop the movement using the opposite direction button. Fine adjustment is possible using the UP and DOWN buttons.
6. Then continue driving in the opposite direction until two short interruptions indicate that the last position has been saved.
7. The learning process is now complete.
8. If necessary, repeat steps 1 to 7 for the other end position.

14. Additional Functions

Deleting a Handheld Transmitter

1. Press and hold the PAIR button on a transmitter that should not be deleted for at least 5 seconds. The drive clicks.
2. Press and hold the PAIR button on the transmitter that should be deleted for at least 10 seconds. The drive clicks, and the transmitter is deleted.

Replacing a Lost Handheld Transmitter

1. Disconnect the drive from the power supply for at least 2 seconds.
2. Reconnect the drive to the power supply for 10 seconds.
3. Disconnect the drive from the power supply again for at least 2 seconds.
4. Reconnect the drive. The drive clicks.
5. If multiple drives click but should not be paired with the new transmitter, deselect them by pressing the STOP button on their respective transmitter. The drives click and exit learning mode.
6. Press and hold the PAIR button on the new transmitter for at least 2 seconds. The drive clicks, and the new transmitter is programmed.



WARNING: The lost transmitter is still stored in the drive's radio module. If you are unsure where the transmitter is, all transmitters can be deleted by resetting the radio module to factory settings.

Resetting the Radio Module to Factory Settings

1. Disconnect the drive from the power supply for at least 2 seconds.
2. Reconnect the drive for 10 seconds.
3. Disconnect the drive again for at least 2 seconds.
4. Reconnect the drive. The drive clicks.
5. If multiple drives click but should not be reset, deselect them by pressing the STOP button on their respective transmitter. The drives click and exit learning mode.
6. Press and hold the PAIR button on a transmitter that is already programmed for at least 7 seconds. The drive clicks once after approx. 2 seconds and a second time after approx. 7 seconds, indicating that the radio module has been reset to factory settings.

Copying Handheld Transmitters Without the Drive

It is possible to copy the functions of one transmitter (master transmitter) onto a new transmitter.

The process must be carried out separately for each button.

Prepare the new transmitter to receive the signal

1. Remove the lower shell of the new transmitter. Briefly press the PAIR button on the new transmitter (A) using a paperclip or similar tool. The LED begins to flash.
2. Within 4 seconds, press and hold the UP button on the new transmitter (A). The LED lights up continuously.

Transfer a button to the new transmitter

1. Keep holding the button on the new transmitter (A) and align the fronts of both transmitters facing each other (maximum distance 5 mm).
2. Press the UP button on the master transmitter (B).
3. As soon as the LED on the new transmitter (A) becomes dimmer, the copying of the UP button is complete and both buttons can be released.

Repeat the procedure for the STOP and DOWN buttons.

Group Formation with the Display Transmitter

Multiple drives can be grouped together on one channel of the display transmitter.

Example:

Drive 1 is programmed on Channel 1, Drive 2 on Channel 2, and Drive 3 on Channel 3. All three drives should be grouped together on Channel 4.

1. Select **Channel 1**.
2. Press and hold the PAIR button for at least 5 seconds. The drive clicks.
3. Select **Channel 4**.
4. Press and hold the PAIR button for at least 5 seconds. The drive clicks — the first drive has been added to the group.
5. Select **Channel 2**.
6. Press and hold the PAIR button for at least 5 seconds. The drive clicks.
7. Select **Channel 4**.
8. Press and hold the PAIR button for at least 5 seconds. The drive clicks — the second drive has been added to the group.
9. Select **Channel 3**.
10. Press and hold the PAIR button for at least 5 seconds. The drive clicks.
11. Select **Channel 4**.
12. Press and hold the PAIR button for at least 5 seconds. The drive clicks — the third drive has been added to the group.

To remove Drive 2 from the group, proceed as follows:

1. Select **Channel 2**.
2. Press and hold the PAIR button for at least 5 seconds. The drive clicks.
3. Select Channel 4.
4. Press and hold the PAIR button for at least 5 seconds. All drives in the group click. The drive from Channel 2 has been removed from the group.

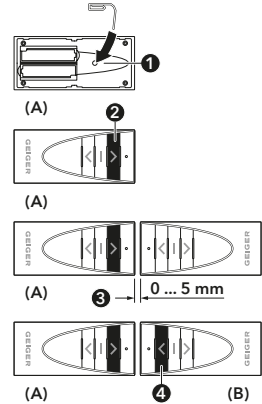

15. Obstacle recognition

When, after the teaching of the first complete, uninterrupted travel from one end position to the other end position is carried out, the torque needed is learnt.



X01 Version: the motor learns the upper end stop on the fifth run upwards to the upper stop. Afterwards, the required torque can be programmed.

In any following complete, uninterrupted travel from end position to end position, the torque needed is automatically reset. Slow changes in the installation due to ageing, soiling, cold or heat are thus automatically taken into consideration.

If a travel movement in UP direction is blocked by an obstacle, the motor switches off and a small return motion takes place.

The running direction in which the obstacle was recognized is blocked.

The block is removed if the motor has been operated in the opposite direction for a certain time. An obstacle must thus first be released before the motor can be operated again in the direction of the obstacle.

16. End position correction



The engine needs to be taught with the end stops (stopper and anti-lift device).

Checking of the end position, and if appropriate an end position correction, takes place after 5, 20, and then every 50 cycles.

Should a hangings elongation have resulted, due to temperature changes, this is corrected at the next end position correction.

If, due to temperature changes, modified winding behaviour should arise and the hangings should run against the stop, an immediate end position correction takes place. In addition, the counter for the end position correction is started afresh.

17. Resetting to factory setting

To reset the drive to the factory setting, press the PROG key for 20 to 30 sec. The drive signals the reset with 4 UP/DOWN movements.

The drive returns to the delivery state.

18. What to do if...

Problem	Solution
Motor does not run.	<ul style="list-style-type: none">• Motor not plugged in. Please check the plug connection.• Check connecting cable for possible damage.• Check the mains voltage and allow the cause of the voltage breakdown to be tested by a specialist electrician.
Instead of in the upwards direction, motor runs downwards.	<ul style="list-style-type: none">• The control leads are interchanged. Exchange black/brown control leads.
Motor only runs in one direction.	<ul style="list-style-type: none">• Motor in the end position. Run motor in the opposite direction. Re-adjust the end positions, if necessary.
After running several times, the motor breaks down and no longer responds.	<ul style="list-style-type: none">• The motor became too hot and has switched off. Try it again after a cooling time of about 15 min.

19. Maintenance

The drive is maintenance-free.

20. Declaration of conformity



EU Declaration of Conformity

Gerhard Geiger GmbH & Co. KG
Antriebstechnik
Schleifmühle 6
D-74321 Bietigheim-Bissingen

Product designation:

Venetian blinds motor, motor for rolling shutters, motor for awnings

Type designation:

GJ56.., GR45.., GU45.., GSI56.., GB35.., GB45.., GB59..

Applied directives:

2006/42/EG
2014/53/EU
2011/65/EU+(EU)2015/863+(EU)2017/2102
(EU)2023/826

Applied standards:

EN 60335-1:2012
EN 60335-1:2012/AC:2014
EN 60335-1:2012/A11:2014
EN 60335-1:2012/A13:2017
EN 60335-1:2012/A1:2019
EN 60335-1:2012/A14:2019
EN 60335-1:2012/A2:2019
EN 60335-1:2012/A15:2021
EN 60335-1:2012/A16:2023

EN 60335-2-97:2006+A11:2008+A2:2010+A12:2015
EN 62233:2008+Ber.1:2008+Cor.:2008

EN IEC 55014-1:2021
EN IEC 55014-2:2021
EN IEC 61000-3-2:2019+EN IEC 61000-3-2:2019/A1:2021
EN 61000-3-3:2013+EN 61000-3-3:2013/A1:2019+EN 61000-3-3:2013/A2:2022

ETSI EN 301 489-1 V2.2.3 (2019-11)
ETSI EN 301 489-3 V2.1.1(2019-03)
ETSI EN 300 220-2 V3.2.1 (2018-06)

Authorized representative for technical data:

Gerhard Geiger GmbH & Co. KG

Address:

Schleifmühle 6, D-74321 Bietigheim-Bissingen

Bietigheim-Bissingen, 19.05.2025



Roland Kraus (General Manager)

10001518 en 0325

Gerhard Geiger GmbH & Co. KG
Schleifmühle 6 | D-74321 Bietigheim-Bissingen
Phone +49 (0) 7142 9380 | Fax +49 (0) 7142 938 230 | info@geiger.de | www.geiger.de
Sitz Bietigheim-Bissingen | Amtsgericht Stuttgart HRA 300591 | USt-IdNr. DE145002146
Komplementär: Geiger Verwaltungs-GmbH | Sitz Bietigheim-Bissingen | Amtsgericht Stuttgart HRB 300481
Geschäftsführer: Roland Kraus, Dr. Bertram Melzig-Thiel | WEEE-Reg.-Nr. DE47902323

EN

Current declarations of conformity are available under www.geiger.de

21. Technical data

Technical data of tubular motor SOLIDline-SOC (GU45..)					
	GU4510	GU4520	GU4530	GU4540	GU4550
Voltage	230 V~/50 Hz				
Current	0,47 A	0,63 A	0,8 A	1,0 A	1,0 A
Cos Phi (cosφ)	>0,95				
Inrush current (factor)	x 1,2				
Power	105 W	140 W	180 W	220 W	220 W
Torque	10 Nm	20 Nm	30 Nm	40 Nm	50 Nm
Speed	16 rpm	16 rpm	16 rpm	16 rpm	12 rpm
Protection class	IP 44				
Total length¹⁾	519,5 mm	549,5 mm	569,5 mm	589,5 mm	589,5 mm
Operating mode	S2 4 min	S2 5 min	S2 4 min	S2 4 min	S2 4 min
Sound pressure level²⁾	39 dB(A)	41 dB(A)	41 dB(A)	43 dB(A)	-
Diameter	45 mm				
Weight	ca. 1,90 kg	ca. 2,20 kg	ca. 2,40 kg	ca. 2,70 kg	ca. 2,70 kg
Air humidity	dry and non-condensing place				
Storage temperature	T = -15°C .. +70°C				

¹⁾ SOLIDline-COM + 0,5 mm

²⁾ The average sound pressure level data are intended for guidance only. The values were determined by GEIGER at a distance of 1 m, with a hanging motor at idle speed and averaged over 10 seconds. There is no reference to any specific test standard.

Subject to technical modifications. Please find information to the ambient temperature range of our GEIGER motors under www.geiger.de

22. Notes on waste disposal

Recycling of packaging materials

In the interest of environmental protection, please contact your local government's recycling or solid waste management department to learn more about the services it provides.

Waste disposal of electric and electronic equipment

Electrical and electronic equipment must be collected and disposed of separately in accordance with EU regulations.

EN

For technical questions, please call our service team at: **+49 (0) 7142 938 333**. They will be happy to assist you.

GEIGER
ANTRIEBSTECHNIK

Gerhard Geiger GmbH & Co. KG
Schleifmühle 6 | D-74321 Bietigheim-Bissingen
T +49 (0) 7142 9380 | F +49 (0) 7142 938 230
info@geiger.de | www.geiger.de

