

Tubular motor:

## **GEIGER-SOLIDline ../55**

Motor control:

## **GEIGER-SoftZeroWireless-55 (GU45..F02)**

for facade awnings, screens and ZIP screens

## **GEIGER-SoftWireless-55 (GU45..F02)**

for side awnings

**EN** Operating Instructions

**EN**

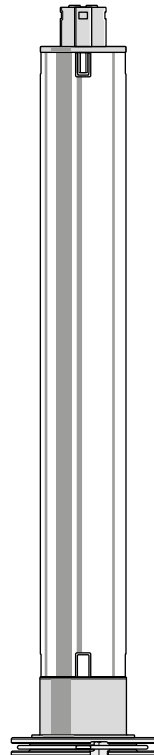

# Index

1. General information .....	4
2. Guarantee.....	4
3. Safety information .....	4
4. Intended use .....	5
5. Installation instructions .....	6
6. Bringing into service .....	6
7. Learning/deleting the radio code.....	7
8. Adjustment of the end positions.....	8
9. Deactivation of the close-range function.....	9
10. Side awnings operation .....	9
11. GEIGER-Powertronic .....	9
12. Function description of radio motor.....	11
13. Radio codes .....	11
14. Obstacle recognition.....	12
15. End position correction .....	13
16. Technical data.....	14
17. Information for the specialist electrician .....	14
18. What to do if... ..	15
19. Notes on waste disposal .....	16
20. Declaration of conformity.....	16

EN

# Characteristics of the **GEIGER-SoftZeroWireless-55** and **GEIGER-SoftWireless-55**

## **Radio-controlled motor for facade awnings and side awnings**

---

- Facade awnings, screens and ZIP screens can be operated with the **GEIGER SoftZeroWireless-55**
- The **GEIGER-SoftWireless-55** is designed exclusively for the operation of side awnings

## **Safety**

---

- A safe locking of the casing through torque shutoff

## **Fabric Protection**

---

- GEIGER-Locking power minimisation (automatic function)
- GEIGER-Powertronic (manual function: power level)

...for a nice long lasting fabric.

## **Hanging Length Adjustment**

---

- Modifications in fabric lengths are recognised and compensated for.

## **Obstacle Recognition**

---

- Active obstacle detection when extending the installation
- Protection of the awning system by retracting the equipment

## **GEIGER-Operating Radius Identification**

---

- Modern electronic control identifies the equipment's torque curve, and makes available to the motor the exact amount of power needed during operation, and while closing.

**EN**

# 1. General information

Dear customer,

By purchasing a GEIGER tubular motor you have decided on a quality product from GEIGER.

Thank you very much for your decision and the confidence placed in us.

Before you put this drive into operation please observe the following safety information. It serves for the prevention of danger and for the avoidance of personal injury and damage to property.

**Please retain this information for future reference.**

- ▶ **For all facade awnings, side awnings, screens and ZIP screens**
- ▶ **Drives are switchable in parallel**
- ▶ **Suitable for all GEIGER radio products**
- ▶ **Automatic detection of right/left installation**

# 2. Guarantee

In the case of incorrect installation contrary to the operating instructions and/or constructional modification, the legal and contractual guarantee for property damage and product liability lapses.

# 3. Safety information



**ATTENTION: Important safety information. For personal safety, it is important to follow these instructions. The instructions should be kept.**

- ▶ **This appliance is not to be used by persons (including children) whose physical, sensorial or mental capacities are impaired, or who have no experience or know-how, unless they have been supervised or been given instructions on the use of the appliance by someone who is responsible for their safety.**
- ▶ **Children must be supervised to make sure they do not play with the appliance.**
- ▶ **The installation is to be checked regularly for defective balance, wear and damage.**
- ▶ **Damaged connecting leads must be replaced by the GEIGER connecting lead of the same wire type.**
- ▶ **During operation observe the danger zone.**
- ▶ **If people or objects are in the danger zone, do not use the installation.**
- ▶ **Urgently shut down damaged installations until repair.**
- ▶ **Unconditionally shut down the unit during maintenance and cleaning operations.**
- ▶ **Pinching and shearing sites are to be avoided and to be safeguarded against.**
- ▶ **When operating the manual actuator with the open sun protection system, exercise caution as it can fall down quickly if springs expand or are broken.**

- ▶ Do not operate the device if operations such as, for example, window cleaning are to be carried out in the vicinity.
- ▶ Disconnect the device from the mains power supply if operations such as, for example, window cleaning are being carried out in the vicinity.



**ATTENTION:** Important safety information. Follow all installation instructions, as incorrect installation can lead to serious injuries.

- ▶ Connection must be carried out by a skilled electrician according to the regulations in force locally.
- ▶ The mains plug of the tubular motor must be accessible after installation.
- ▶ On the installation of the tubular motor without mechanical protection of the driven parts, the tubular motor must be installed at a height of at least 2.5 m above the ground or of another level which provides access to the drive.
- ▶ Before the tubular motor is installed, all leads which are not needed are to be removed and all equipment which is not needed for actuation is to be put out of operation.
- ▶ If the tubular motor is controlled by a switch or pushbutton, the switch or pushbutton must be mounted within eyeshot of the tubular motor. The switch or pushbutton must not be located in the vicinity of moving parts. The height of installation must be at least 1.5 m above the floor.  
If the apparatus is equipped without a pin and a socket connector (STAS3K) in the connecting lead, or other means for disconnecting from the mains with at least a 3 mm contact opening on each pole, a disconnecting device of this type must be incorporated into the permanently installed electrical installation according to the wiring rules.
- ▶ Permanently installed control devices must be attached visibly.
- ▶ The correct dimensioning of the drive is to be observed.

**We recommend the following procedure:**

1. Installation of the motor .....	(Chapter 5).....	Page 6
2. Bringing into service.....	(Chapter 6).....	Page 6
3. Teaching the radio code.....	(Chapter 7).....	Page 7
4. Teaching the end positions .....	(Chapter 8).....	Page 8

## 4. Intended use

The tubular motors of the model range **SOLIDline .. /55** with the **SoftZero-Wireless-55** system are designed exclusively for the operation of facade awnings, screens and ZIP screens.

The radio control **SoftWireless-55** is designed exclusively for the operation of side awnings.

If the tubular motors are used for other applications and/or modifications are performed to the tubular motors, which have not been discussed with GEIGER Antriebstechnik, then the manufacturer is **not** liable for personal injury and/or damage to property and for consequential damage.

## 5. Installation instructions

Before fixing, the strength of the masonry or of the subsurface is to be checked.



**Caution: If the tube is screwed/riveted to the drive, the measure must be taken from the tube end to the center of the drive and marked on the tube.**

When drilling the winding shaft never drill into the area of the tubular motor!

When inserting into the shaft, the tubular motor must not be struck and must not be allowed to fall into the shaft.

### Installation into facade awnings and screens:

Insert motor with a suitable adapter and drive into the shaft up to the stop of the shaft adapter.

Fix the motor support on the awning. Fix the motor together with the shaft on the motor support. The bearer locks into place.

### Depending on the selected motor head, different fixation systems can be used:

- Place the motor with square insert in the star-shaped bearer and lock with pin
- Place the motor into the existing engine bearer and lock
- Place the motor in a compatible engine bearer with clip system and lock with spring or rotating lever

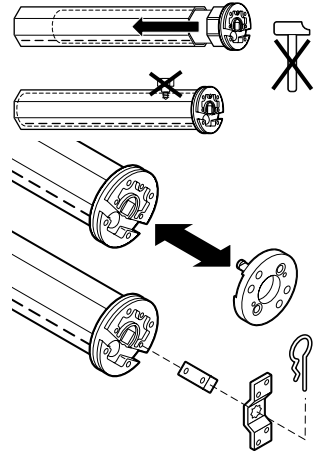

## 6. Bringing into service

### Definition of „near range“:

Distance of the hand-held transmitter to the motor control: max. 15 cm,

or

hold at the hand-held transmitter directly on to the motor-connecting cable.

The motor-connecting cable thus serves up to a length of 3 metres as an “antenna”.

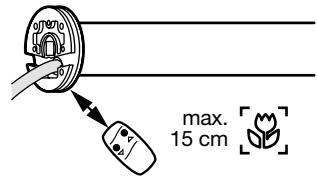

### Definition of „far range“:

Distance of the hand-held transmitter to the motor control: min. 1.5 metres,

and

Distance of the hand held transmitter to the motor connecting cable min.0.5 metres

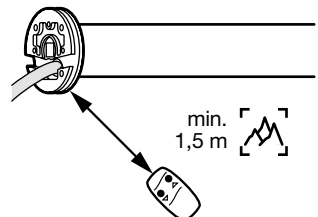

Connect the motor to the power grid.

Switch on the mains.

The motor makes a short back and forth movement (1 x „click-click“).

After each interruption of the voltage supply, the learning mode **can** be activated for 30 min.



**The learning mode is necessary in order to transmit radio codes, or in order to be able to adjust the end positions.**

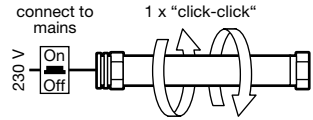

### Activate learning mode:

In the near range press UP or DOWN key and keep it pressed for about 3 seconds until the motor actuates (1 x “click-click”).



**If no action takes place within 60 seconds, the learning mode is deactivated! The motor returns to normal operation (3 x „click-click“).**

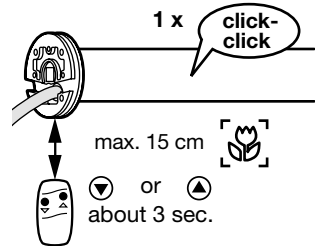

## 7. Learning/deleting the radio code



**The learning mode must be activated first in order to learn the radio codes.**

In the close range press UP or DOWN key for about 1 second. The motor actuates. (1 x “click-click”).

**The remote code is taught to the motor!**

**The learning mode is now concluded.**

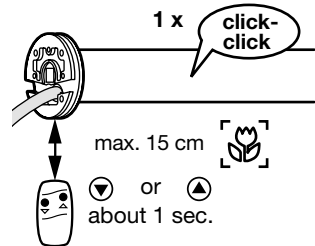

### Deleting the radio code



**The learning mode must be activated first in order to delete the radio codes.**

At close range, press the UP or DOWN key and hold approx. 5 seconds. The motor reacts immediately (1 x ‘Click-Click’).



**Please note:  
You can only delete all remote codes and sensor remote codes together. It is not possible to delete individual remote codes.**

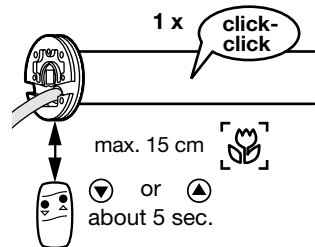

## 8. Adjustment of the end positions



It is required for the upper end position to act as a stopper for torque deactivation (e.g. casing contour).



In order to adjust the end position, the learning mode must first be activated (see chapter 7)!!

### Activating the end position mode:

From far range, press the up or down button and hold until you hear the motor (1 x 'Click-Click').



Please note! The correct button allocation for up and down happens automatically after programming of the end position is complete.

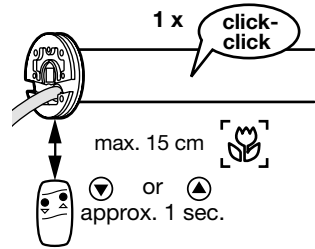

### Adjusting the Lower End Position



The lower end position must be adjusted first.

From far range, press the up or down button and hold until the installation has reached the desired end position.

Corrections are possible with the up and down buttons.

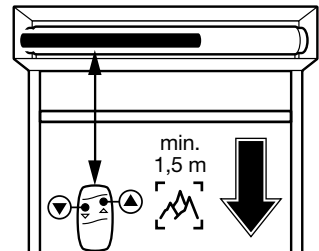

### Saving the lower end position:

From close range, press the up or down button and hold approx. 1 second, then release.

The motor responds (1 x 'Click-Click').

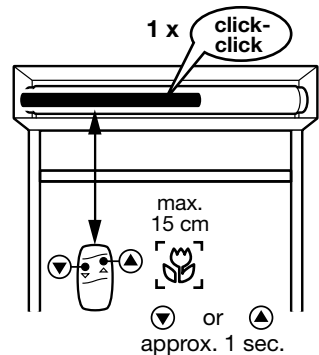

## Adjusting the Upper End Position

From far range, press the up or down button and hold approx. 3 seconds until the installation retracts and locks.

As soon as the upper end position is reached, the motor automatically turns off and the upper end position is saved. You will hear the motor (1 x 'Click-Click'). The up and down buttons are now assigned to the corresponding turning direction of the motors!

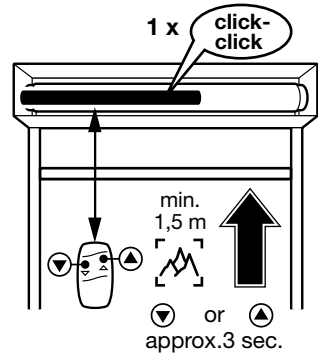

The learning mode is now concluded.



**Finally, conduct at least one trial run, so that the motor electronics can automatically detect the threshold of the torque disconnection.**

## 9. Deactivation of the close-range function

If two motors are installed so that both trigger in the close range, there is the option of deactivating the close-range function in one of the two motors.



**The prerequisite is that the motors must be assigned to different button pairs!**

To deactivate the close-range function, move the desired hanging to the upper end position, push the „UP“ button and keep it pushed for about 5 seconds until the motor confirms (2 x „click-click“).

The motor must be disconnected from the mains briefly to active the close-range function.

## 10. Side awnings operation

After the tensioning of the cloth on the outer end position retract the awning until the motor disconnects via torque recognition.

A perfect tensioning of the cloth is thus ensured.

EN

## 11. GEIGER-Powertronic

The GEIGER-Powertronic enables the user to change the motor's closing characteristics. The user can raise or reduce the closing power applied through the motor. This way, he or she influences the closing characteristics of the casing. A rise in the closing power causes a tighter closing of the casing with increased stress on the fabric; a reduction in the closing power causes a looser closing and less strain to the fabric.

**Closing power levels:** from level 0 to level 7

**GEIGER-delivery setting:** level 0



**Caution: By manually raising the closing power (e.g. from level 0 to level 7) the fabric endures more strain.**

### In which situations is the GEIGER-Powertronic applied?

- If the closing operation should be optimised for better fabric protection.

### When can the GEIGER-Powertronic be applied?

- Anytime; this function can be activated during initial operation, as well as at a later date.

### Which resources are necessary?

- GEIGER-hand-held remote, which is taught-in in accordance with chapter 7.

### Please note:

- The end positions are not affected when the GEIGER-Powertronic is activated.
- Only activate the GEIGER-Powertronic after the end positions have been taught-in and a complete trial has been conducted.

### Activating the GEIGER-Powertronic:

1. At close range, press the 'Up' or 'Down' button and hold approx. 3 seconds until you hear the motor (1 x 'Click-Click').

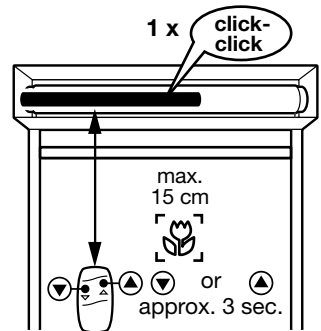

2. From far range, press the 'Up' or 'Down' button and hold approx. 1 second until you hear the motor (1 x 'Click-Click').

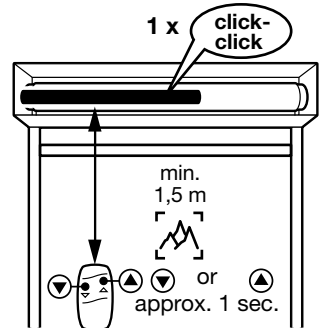

3. At close range, press the 'Up' or 'Down' button and hold approx. 3 seconds until you hear the motor (1 x 'Click-Click').

Now the power can be incrementally increased with the 'Up' button and incrementally reduced with the 'Down' button.

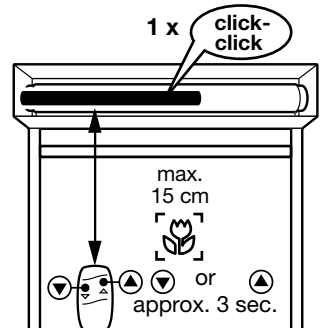

4. When the desired power level is reached, at close range, press the 'Up' or 'Down' button and hold approx. 1 second. The motor is now in its normal operating mode. (1 x 'Click-Click').

**The learning mode is now concluded.**



**As soon as the lowest or highest power level has been reached and you try to continue to raise or lower the level, you will hear a signal from the motor (2 x 'Click-Click').**

Should there be no activity for 60 seconds, learning mode will be deactivated. The power level set will be assumed!

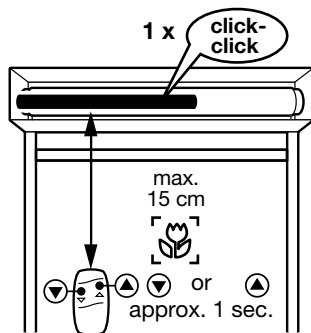

## 12. Function description of radio motor

In the delivery state, each GEIGER radio receiver and radio transmitter is equipped with the "GEIGER-Code" + + + + - - so that the motor can be operated immediately, in order, for example, to facilitate the installation of hangings on the winding shaft.



**For security reasons, the „GEIGER-Code“ must be overwritten by an individual code! This takes place automatically in the teaching for the first time of an individual code (see chapter 7 learn/delete radio codes).**

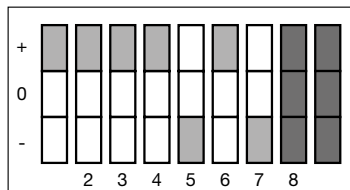

„GEIGER code“

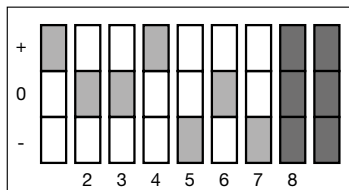

individual code (example)

**The DIP switches No. 8 and No. 9 have no function!**

Please take the description and adjustments from the operating instructions of the appropriate hand-held/wall transmitter.

EN





## 13. Radio codes

A maximum of three different functional codes can be taught. The motor can thus be a member in three groups that are independent of one another. Additionally, a further two radio sensor codes can be taught.

If three radio codes have already been taught and it is attempted to teach a fourth code, the radio code learnt as the third code is cancelled and replaced by the new code. If two radio sensor codes have already been taught and it is attempted to teach a third code, the radio sensor code learnt as the second code is cancelled and replaced by the new code.

**Example:**

**Wireless receiver in the motor**

Group 1 Code	Group 2 Code	Group 3 Code	Sensor 1 Code	Sensor 2 Code
+ 0 0 + - 0 -	+ + + 0 0 + +	+ - + + - + +	+ - + + - + +	+ + + - - + +
				

**For your documentation record any hand-held remote/sensor codes taught into the motor here:**

Group 1	Group 2	Group 3	Sensor 1	Sensor 2
_____	_____	_____	_____	_____

**Programming in the far range/near range**

In the radio receiver of the motor is integrated an approach detector that recognizes whether a radio transmitter is operated from some distance = far range, (at least 1.5 metres distance to the motor control or 0.5 metres to the motor cable), or it is operated close to the antenna = near range, (at most 15 cm removed or directly on the motor connecting cable).



**Caution: If radio receivers or motor connecting cables lie near to one another, unintentional codes can be transmitted to other radio receivers.**

**Recommendation:**

When starting the motor for the first time, disconnect motors that are intended to be operated by another pair of keys, or by another code, from the mains.

**EN 14. Obstacle recognition**

When, after the teaching of the first complete, uninterrupted travel from one end position to the other end position is carried out, the torque needed is learnt.

In any following complete, uninterrupted travel from end position to end position, the torque needed is automatically reset. Slow changes in the installation due to ageing, soiling, cold or heat are thus automatically taken into consideration.

If a travel movement in UP or DOWN direction is blocked by an obstacle, the motor switches off and a small return motion takes place (no return motion with the SoftWireless-55).

The running direction in which the obstacle was recognized is blocked.

The block is removed if the motor has been operated in the opposite direction for a certain time. An obstacle must thus first be released before the motor can be operated again in the direction of the obstacle.

**Because of the motor sensitive obstacle detection, the correct dimensioning of the torque for the respective installation size is essential.**

In the following table please find a selection aid to find out the right motor size:

		Weight of bottom bar [kg]												
Winding diameter [mm]	1	2	3	4	5	6	8	10	12	15	20	25	30	
	50	0,2	0,5	0,7	1,0	1,2	1,5	2,0	2,5	2,9	3,7	4,9	6,1	7,4
	55	0,3	0,5	0,8	1,1	1,3	1,6	2,2	2,7	3,2	4,0	5,4	6,7	8,1
	60	0,3	0,6	0,9	1,2	1,5	1,8	2,4	2,9	3,5	4,4	5,9	7,4	8,8
	65	0,3	0,6	1,0	1,3	1,6	1,9	2,6	3,2	3,8	4,8	6,4	8,0	9,6
	70	0,3	0,7	1,0	1,4	1,7	2,1	2,7	3,4	4,1	5,2	6,9	8,6	10,3
	75	0,4	0,7	1,1	1,5	1,8	2,2	2,9	3,7	4,4	5,5	7,4	9,2	11,0
	80	0,4	0,8	1,2	1,6	2,0	2,4	3,1	3,9	4,7	5,9	7,8	9,8	11,8
	85	0,4	0,8	1,3	1,7	2,1	2,5	3,3	4,2	5,0	6,3	8,3	10,4	12,5
	90	0,4	0,9	1,3	1,8	2,2	2,6	3,5	4,4	5,3	6,6	8,8	11,0	13,2
	95	0,5	0,9	1,4	1,9	2,3	2,8	3,7	4,7	5,6	7,0	9,3	11,6	14,0
	100	0,5	1,0	1,5	2,0	2,5	2,9	3,9	4,9	5,9	7,4	9,8	12,3	14,7
	110	0,5	1,1	1,6	2,2	2,7	3,2	4,3	5,4	6,5	8,1	10,8	13,5	16,2
		3 Nm				6 Nm			9 Nm			12 Nm		

These are estimated values so please check the correct functioning of the installation.



**When using a wind sensor (GF0024/GF0025) the correct functioning of the retract command under wind load should be checked by the manufacturer of the sun protection before commissioning.**

## 15. End position correction

If a **lengthening/shortening of the hanging** has resulted due to e.g. temperature changes, this will be automatically corrected by closing the awning.

If, due to temperature changes, an **adjusted sleeve performance** is set and the hanging runs against the stop unit, the end position is immediately corrected.

After the first trial, the motor automatically identifies the torque necessary to close the awning and closes it with the lowest possible power, so that the fabric is optimally protected.

## 16. Technical data

Technical data of short motor SOLIDline-KS (GU45..)				
	GU4503/55	GU4506/55	GU4509/55	GU4512/55
<b>Voltage</b>	230 V~/50 Hz	230 V~/50 Hz	230 V~/50 Hz	230 V~/50 Hz
<b>Current</b>	0,47 A	0,63 A	0,8 A	1,0 A
<b>Cos Phi (cosφ)</b>	>0,95	>0,95	>0,95	>0,95
<b>Inrush current (factor)</b>	x 1,2	x 1,2	x 1,2	x 1,2
<b>Power</b>	105 W	140 W	180 W	220 W
<b>Torque</b>	3 Nm	6 Nm	9 Nm	12 Nm
<b>Speed of rotation</b>	55 1/min	55 1/min	55 1/min	55 1/min
<b>Protection type</b>	IP 44	IP 44	IP 44	IP 44
<b>Total length<sup>1)</sup></b>	515,5 mm	545,5 mm	565,5 mm	585,5 mm
<b>Operating type</b>	S2 4 min	S2 5 min	S2 4 min	S2 4 min
<b>Diameter</b>	45 mm	45 mm	45 mm	45 mm
<b>Weight</b>	approx. 1,9 kg	approx. 2,2 kg	approx. 2,4 kg	approx. 2,7 kg

<sup>1)</sup> SOLIDline-ZN +1 mm / SOLIDline-COM/-SIC + 4,5 mm / SOLIDline-SOC: + 4 mm

Subject to technical modifications



## 17. Information for the specialist electrician



**Caution:**  
Wrong installation and wrong connection  
can lead to serious injuries.

The parallel operation of the several **SOLIDline SoftZeroWireless-55/SOLIDline SoftWireless-55** is possible.

PVC cables are not suitable for equipment used outdoors or exposed to prolonged high levels of UV radiation.

These cables should not be used if they are likely to touch metal parts that can heat up to temperatures exceeding 100°C.

Connecting cables with plug connectors of the Hirschmann Company, type STAS 3K or the Phoenix Mecano Company, type GLS/3+PE may only be used in connection with the Hirschmann cable socket STAK 3K.

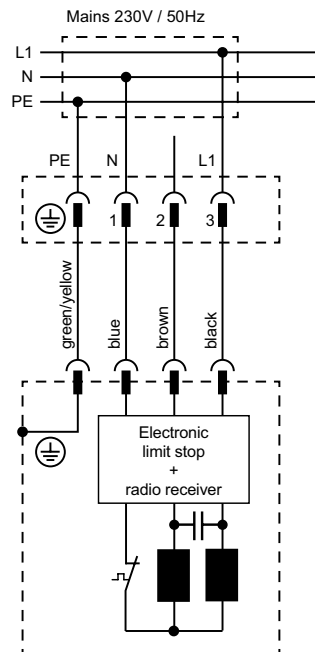

EN

## 18. What to do if...

Problem	Solution
<p><b>No short “click-click“ on switching on the motor.</b></p>	<ul style="list-style-type: none"> <li>• Motor not plugged in. Please check the plug connection. Check connecting cable for possible damage.</li> <li>• Check the mains voltage and allow the cause of the voltage breakdown to be tested by a specialist electrician.</li> </ul>
<p><b>Hand-held transmitter does not work.</b></p>	<ul style="list-style-type: none"> <li>• Check the battery.</li> <li>• The wind sensor has triggered. Try it again after the expiry of the wind cut-off time.</li> <li>• Inadvertent deletion of the radio code. Start learning radio code again (see chapter 7).</li> </ul>
<p><b>After running several times, the motor breaks down and no longer responds.</b></p>	<ul style="list-style-type: none"> <li>• The motor became too hot and has switched off. Try it again after a cooling time of about 15 min.</li> </ul>
<p><b>The motor no longer runs automatically.</b></p>	<ul style="list-style-type: none"> <li>• The sun automatic control mechanism was switched off.</li> <li>• The wind sensor has triggered. Try it again after the expiry of the wind cut-off time.</li> <li>• Inadvertent deletion of the radio code. Start learning radio code again (see chapter 7).</li> </ul>
<p><b>The motor does not react to the near range</b></p>	<ul style="list-style-type: none"> <li>• Move as close as possible to the motor head with the hand-held transmitter.</li> <li>• Exchange the batteries in the hand-held transmitter.</li> <li>• The close range is deactivated. To activate the close range disconnect the motor from the electrical supply for about 3 seconds.</li> </ul>
<p><b>The motor stops between the upper and the lower end stop.</b></p>	<ul style="list-style-type: none"> <li>• The motor has detected an obstacle. Please remove the obstacle. The device will be unlocked if the motor is run for a short time period in the opposite direction.</li> </ul>

## 19. Notes on waste disposal

### Recycling of packaging materials

In the interest of environmental protection, please contact your local government's recycling or solid waste management department to learn more about the services it provides.

### Waste disposal of electric and electronic equipment

Electronic equipment or batteries cannot be discarded along with the normal household waste. Keep for more information on the recycling and disposal methods envisaged by the local regulations in your area.

## 20. Declaration of conformity

We herewith explicitly declare that this product complies with the essential requirements and relevant directives. It is authorised for use in all EC member states and in Switzerland without any need of prior registration. The Declaration of Conformity concerning this product is available on our website: [www.geiger-antriebstechnik.de](http://www.geiger-antriebstechnik.de).

EN

**For technical questions, please call our service team at: +49 (0) 7142 938-300.  
They will be happy to assist you.**



**Gerhard Geiger GmbH & Co. KG**

Schleifmühle 6

D-74321 Bietigheim-Bissingen

Telephone: +49 (0) 7142 938-0

Telefax: +49 (0) 7142 938-230

[www.geiger-antriebstechnik.de](http://www.geiger-antriebstechnik.de)

[info@geiger-antriebstechnik.de](mailto:info@geiger-antriebstechnik.de)