



ROLLER SHUTTERS

MECHANICAL
DRIVE SOLUTIONS

GEIGER
ANTRIEBSTECHNIK

Dimensioning of rolling shutter drives

In the following, we would like to provide you with help for the correct design of a rolling shutter drive. Several components must be considered:

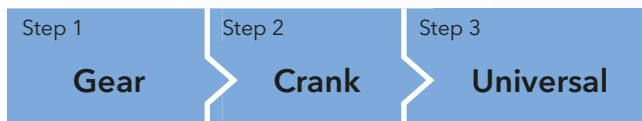

- **Rolling shutter gearbox**
What maximum output torque and reduction ratio must or should be used?
- **Crank handles/rods**
Determine the suitable crank working radius for an easy operation according to standard?
- **Spherical bearing**
What spherical bearing is suitable for the loads that occur?

Our service for the rolling shutter manufacturer – the right drive for the rolling shutter.

Our service:

We can “measure” rolling shutters for you. Our measurements are to record the “load profile” of the rolling shutter during an on-site inspection. Based on this, we can choose the right drive for the respective rolling shutter element with and for you.

Your advantage:

We find that rolling shutters are fitted with oversized drives time and time again. We strive to work with our customers to select the most economical and technically optimal drive. If you don't do this, you are giving away money.

Step 1: Calculation of the required output torque with the aid of a “constant”

In order to simplify the calculation of the required output torque and make it more reliable, constants for the calculation were determined through extensive series of tests. The gearbox is selected in several steps:

Determination of the curtain weight

Width of the hanging in m x **Height** of the hanging in m x **sqm Weight** of the profile used in kg (manufacturer's specification) = **Curtain weight in kg**

Selection of the appropriate constant determined by the hanging height, the profile used and the tube used

	Profile	Mini profile (8 mm)	Maxi profile (14 mm)	
Hanging height	Tube	40 mm tube Octagonal tube	60 mm tube Octagonal tube	
		up to 140 cm	0.35	0.60
up to 240 cm		0.42	0.60	0.65

Calculation of the output torque

Curtain weight x **constant value** = required **output torque** of the gearbox

Select your gearbox based on the output torque from the overview on the following page or on the product pages.

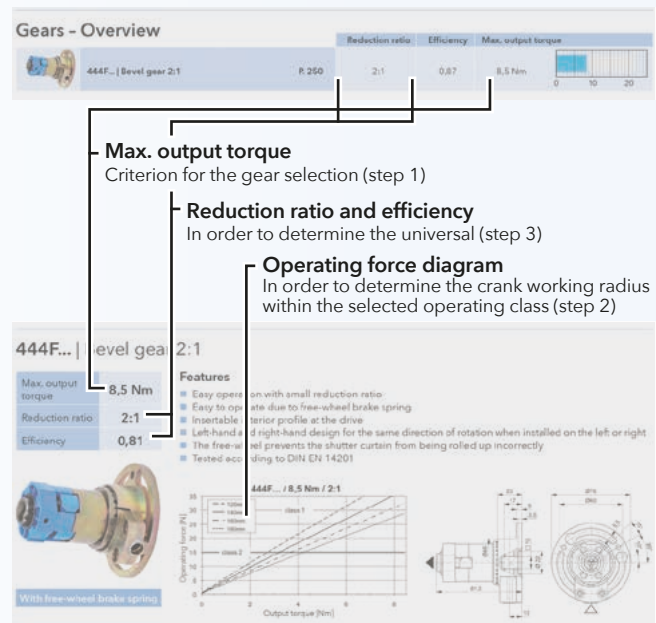

You will find on the product data sheets the gear-specific information for the dimensioning of rolling shutter operating systems.

Example:

A rolling shutter with a width of 125 cm and a height of 220 cm is used for a door element. A mini profile on a 60 mm tube is used as a blind. The specific curtain weight is 3.4 kg per m². Class 1 operation is required.

Sample calculation:

Calculation of the curtain weight:

$$1.25 \text{ m} \times 2.20 \text{ m} \times 3.4 \text{ kg} = 9.35 \text{ kg}$$

Calculation of the output torque:

$$9.35 \text{ kg} \times 0.6 \text{ (constant value)} = 5.6 \text{ Nm}$$

The "constant value" includes the conversion from kg to Newton, the effective lever length and a safety margin for friction.

Note that various mechanical factors play a role in the calculation of the output torque, which cannot be taken into account in this "constant value".

These include:

- Shaft geometry and shape used
- Geometry and winding behaviour of the rolling shutter slats
- Run-in behaviour in the guide rails
- Different piping materials
- Friction in the overall system

Therefore, the results are approximate values for which we cannot provide any guarantee. The exact values can only be determined by an experienced technician.

Step 2: Determining the suitable crank working radius

For normal operation the force needed at the crank handle should not exceed 30 N (corresponds to about 3 kg). This force corresponds to **the operating class 1 according to DIN EN 13659**.

For light and comfortable operation the force needed at the crank handle should not exceed 15 N (corresponds to about 1.5 kg). This force corresponds to **operating class 2** according to DIN EN 13659.

The operating force diagram which you will find with the selected gear helps you find out the required crank working radius according to the above classes.

Example: Gear 444F... with a 8.5 Nm output torque and a 2:1 reduction ratio

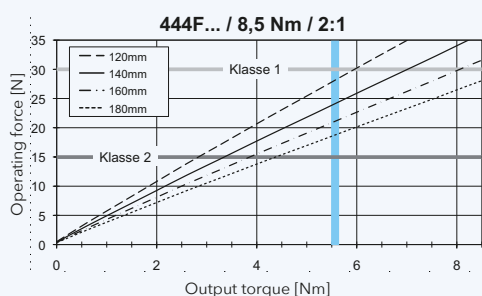

As shown with the blue lines, the class 1 is reached with a crank working radius of 120 mm!

Step 3: Calculation of the spherical plain bearing

It is important to know the resulting torque at the universal joint when dimensioning the spherical bearing. The output torque calculated in step 1 is calculated with the values (reduction ratio and efficiency) of the gearbox after selecting the gearbox.

Calculation of the spherical joint torque:
 (Output torque : gear reduction) : Efficiency =
 spherical plain bearing torque

A different gear with a higher output torque and / or another reduction ratio must be selected in order to reach the class 2.

Alternative: Gear 446F... with 9 Nm output torque and a reduction ratio of 3:1

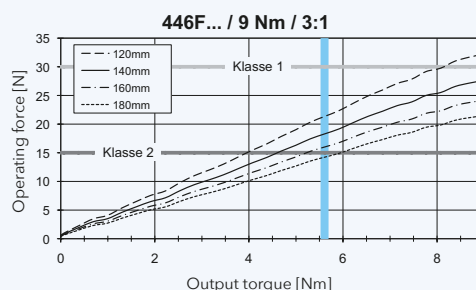

Due to the reduction of the gearbox (3:1), the operating class with a working radius of 180 mm, operating class 2 can be achieved.

Example:

The selected gearbox 446F... has a reduction ratio of 3:1 (3 : 1 = 3) and an efficiency of **0.86**.

Sample calculation:

Calculation of the spherical plain bearing torque:
 (5.6 Nm : 3) : 0.86 = **2.17 Nm**

Up to 3 Nm spherical plain bearing torque, a spherical plain bearing 816F... made of steel can be used. A spherical plain bearing 818F... made of aluminium must be used between 3 and 5 Nm.

Colour specifications and print presentation

The colours specified and shown in the catalogue are only reference values. RAL colours may deviate from the RAL specifications depending on the surface or base material. The colour fields shown in the tables may be displayed differently due to printing-related deviations.

Drawings and dimensions











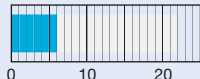

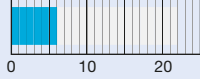

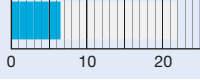

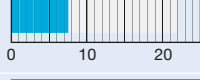

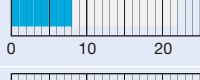

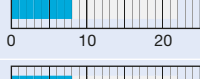

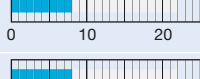

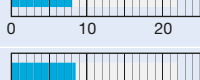

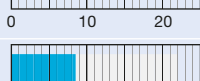

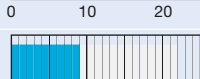

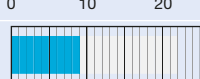

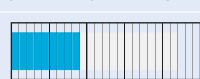

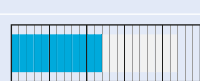

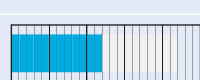
The technical drawings shown in this catalogue refer to a product from a series.

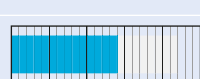
Dimensions from the drawings cannot be used for all items in some cases.

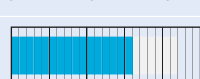
If required, please request exact dimensional drawings for the selected item.

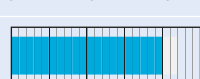
Technical changes and errors excepted

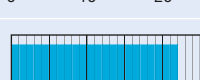
Drive overview

			Gear reduction	Efficiency	Max. output torque	
	462F... Bevel gearbox 2.7:1	P. 235	2.7:1	0.66	6.0 Nm	
	415F... Worm gear 4.33:1	P. 215	4.33:1	0.36	6.0 Nm	
	414F... Worm gear 4:1	P. 214	4:1	0.39	6.5 Nm	
	421F5... Worm gear 5.33:1	P. 220	5:1	0.40	7.5 Nm	
	419F5... Worm gear 6:1	P. 217	6:1	0.46	8.0 Nm	
	419F... Worm gear 5.33:1	P. 216	5.33:1	0.45	8.0 Nm	
	419F55... Worm gear 5.7:1	P. 217	5.7:1	0.36	8.0 Nm	
	414F... Worm gear 6:1	P. 214	6:1	0.31	8.0 Nm	
	444F... Bevel gearbox 2:1	P. 226	2:1	0.87	8.5 Nm	
	444F6... Reversible bevel gearbox 2:1	P. 226	2:1	0.65	8.5 Nm	
	446F... Bevel gearbox 3:1	P. 228	3:1	0.86	9.0 Nm	
	446F6... Reversible bevel gearbox 3:1	P. 228	3:1	0.61	8.5 Nm	
	447F... Bevel gearbox 3:1	P. 232	3:1	0.65	9.0 Nm	
	456F... Bevel gearbox 4:1	P. 230	4:1	0.85	12.0 Nm	
	456F6... Reversible bevel gearbox 4:1	P. 230	4:1	0.66	12.0 Nm	
	461F... Bevel gearbox 5:1	P. 233	5:1	0.77	14.0 Nm	
	419F... Worm gear 8:1	P. 216	8:1	0.40	16.0 Nm	
	421F8... Worm gear 8:1	P. 222	8:1	0.39	20.0 Nm	
	460F... Bevel gearbox 8:1	P. 233	8:1	0.75	22.0 Nm	

Venetian blinds and external blinds

Rolling shutter

Textile sun protection

System components

414F... | Worm gear 4:1

Max. output torque	6.5 Nm
Gear reduction	4:1
Efficiency	0.39

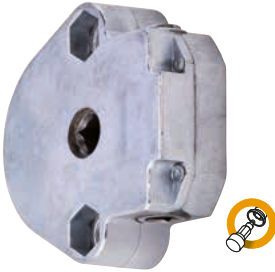

Characteristics

- The small power pack: maximum performance with minimal gearbox dimensions
- With end stop (AB) after max. 19 revolutions (also available without end stop)
- Continuous internal profile on the drive and output
- Matching freewheel and tube driver 414F9.

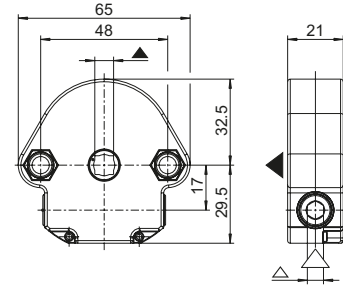
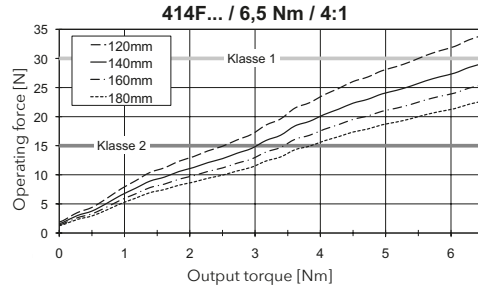

Part no.	End stop (AB)	Drive Δ	Output ∇
414F002	with AB	6 mm	6 mm
414F008	with AB	6 mm	7 mm
414F011	without AB	6 mm	7 mm
414F012	with AB	6 mm	7 mm
414F023	without AB	6 mm	7 mm
414F024	with AB	6 mm	7 mm
414F039	with AB	8 mm	7 mm
414F040	with AB, left-hand roller	6 mm	12 mm, L=130 mm
414F043	with AB, right-hand roller	6 mm	12 mm, L=130 mm

414F... | Worm gear 6:1

Max. output torque	8.0 Nm
Gear reduction	6:1
Efficiency	0.31



Characteristics

- The small power pack: maximum performance with minimal gearbox dimensions
- With end stop (AB) after max. 19 revolutions (also available without end stop)
- Continuous internal profile on the drive and output
- Matching freewheel and tube driver 414F9.

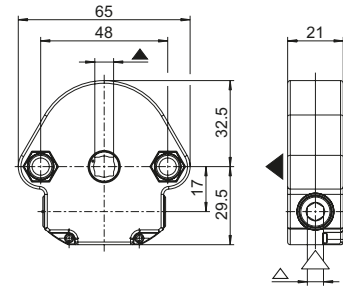
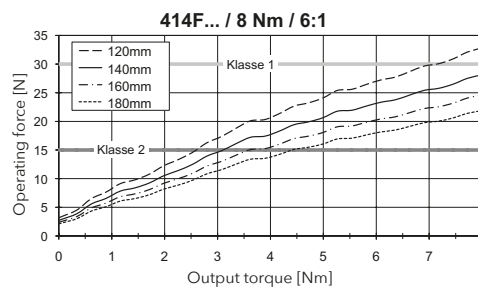

Part no.	End stop (AB)	Drive Δ	Output ∇
414F602	with AB	6 mm	7 mm
414F624	with AB	6 mm	7 mm
414F625	without AB	6 mm	7 mm
414F630	with AB, left-hand roller	6 mm	12 mm, L=130 mm
414F631	with AB, right-hand roller	6 mm	12 mm, L=130 mm
414F643	without AB	6 mm	7 mm

414F906 | Freewheel

Characteristics

- For worm gear 414F... (max. 8 Nm)
- Prevents incorrect winding of the rolling shutter curtain
- One version for left or right installation
- Stop disc available as mounting stop for rolling shutter tube

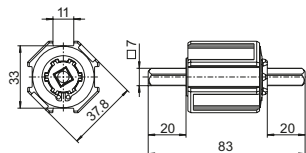

Part no.	Drive	Output	Comment
414F906	■ 7 mm	● 37.8 mm	Freewheel left and right

414F9.. | Tube driver

Characteristics

- For worm gear 414F...

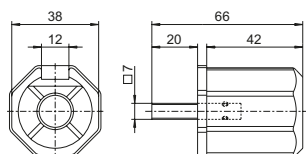

Part no.	Drive	Output
414F900	■ 7 mm	● 38 mm

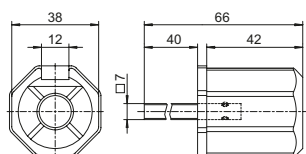

Part no.	Drive	Output
414F902	■ 7 mm	● 38 mm

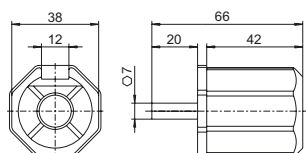

Part no.	Drive	Output
414F909	● 7 mm	● 38 mm

415F... | Worm gear 4.33:1

Max. output torque	6.0 Nm
Gear reduction	4.33:1
Efficiency	0.36

Characteristics

- Zinc die-cast housing
- Continuous internal profile on the drive and output
- Without end stop (AB)

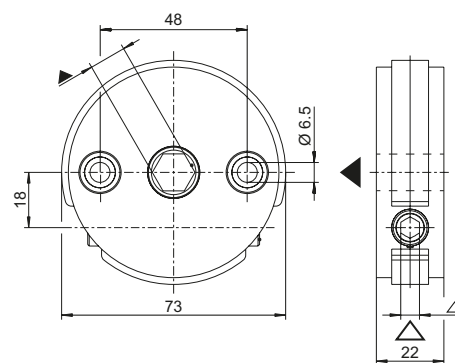
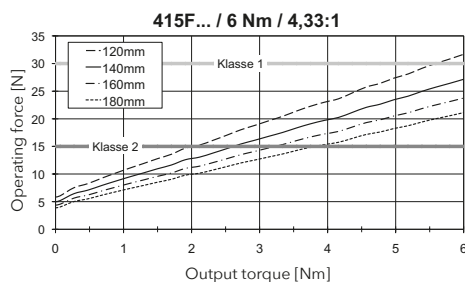

Part no.	Drive ▲	Output ▼	Installation side
415F001	○ 6 mm	○ 12 mm	left
415F003	○ 6 mm	○ 10 mm	left
415F007	○ 6 mm	○ 10 mm	left
415F002	○ 6 mm	○ 12 mm	right

419F... | Worm gear 5.33:1

Max. output torque	8 Nm
Gear reduction	5.33:1
Efficiency	0.45



Characteristics

- Housing of high-strength plastic
- Can be used universally with adapter systems
- Continuous internal profile on the drive and output
- One version for left or right installation
- Can also be mounted in side panels with bearing pins
- Matching freewheel and tube driver 419F9.
- Without end stop (AB)

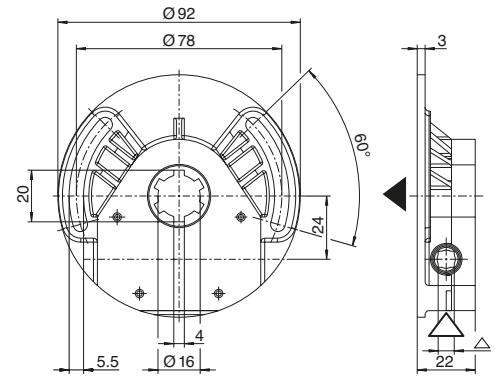
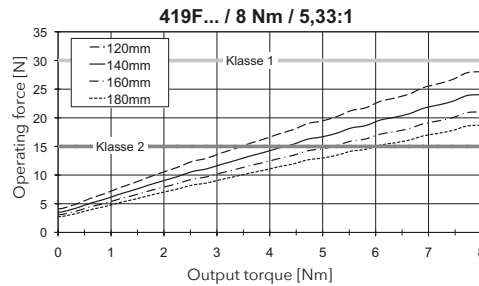

Part no.	Drive \triangle	Output ∇
419F003	\bigcirc 6 mm	\star 16 mm

419F... | Worm gear 8:1

Max. output torque	16 Nm
Gear reduction	8:1
Efficiency	0.40



Characteristics

- Housing of high-strength plastic
- Can be used universally with adapter systems
- Continuous internal profile on the drive and output
- One version for left or right installation
- Can also be mounted in side panels with bearing pins
- Matching freewheel and tube driver 419F9.
- Without end stop (AB)

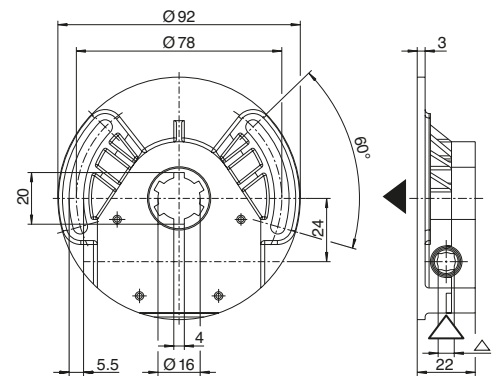
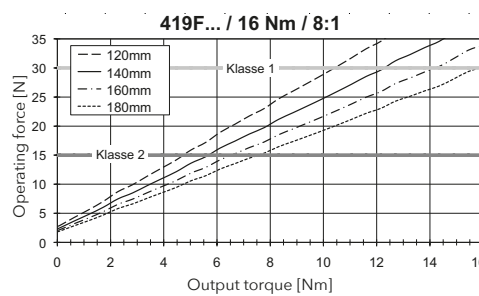

Part no.	Drive \triangle	Output ∇
419F001	\bigcirc 6 mm	\star 16 mm
419F012	\bigcirc 7 mm	\star 16 mm

419F5.. | Worm gear 6:1

Max. output torque	8 Nm
Gear reduction	6:1
Efficiency	0.46

Characteristics

- With and without end stop (AB)
- One version for left or right installation
- Continuous internal profile on the drive and output
- Housing of high-strength plastic
- Hardened steel worm, die-cast zinc worm wheel
- Can be used universally with adapter systems
- Can also be mounted in side panels with bearing pins
- Matching freewheel and tube driver 419F9.

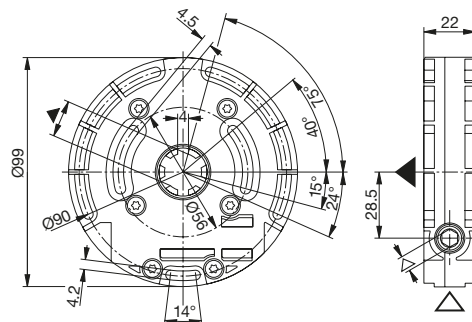
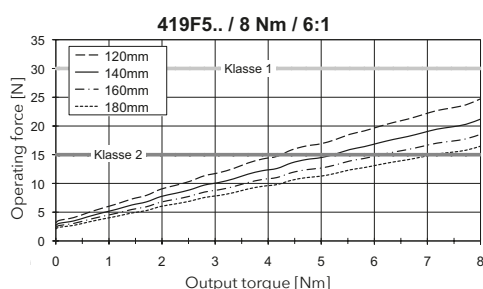

Part no.	End stop (AB)	Drive Δ	Output ∇
419F500	with AB	8 mm	16 mm
419F501	without AB	8 mm	16 mm
419F502	with AB	6 mm	16 mm
419F503	without AB	6 mm	16 mm
419F504	with AB	7 mm	16 mm
419F508	with AB	8 mm	10 mm
419F511	without AB	7 mm	10 mm
419F515	with AB	8 mm	13 mm

419F55. | Worm gear 5.7:1

Max. output torque	8 Nm
Gear reduction	5.7:1
Efficiency	0.36

Characteristics

- Integrated overload clutch (on both sides) on the drive protects against incorrect operation and prevents the hanging from being wound up incorrectly
- With and without end stop (AB)
- One version for left or right installation
- Continuous internal profile on the drive and output
- Can also be mounted in side panels with bearing pins
- Can be used universally with adapter systems
- Housing of high-strength plastic
- Plastic worm and worm wheel
- Matching tube driver 419F9.

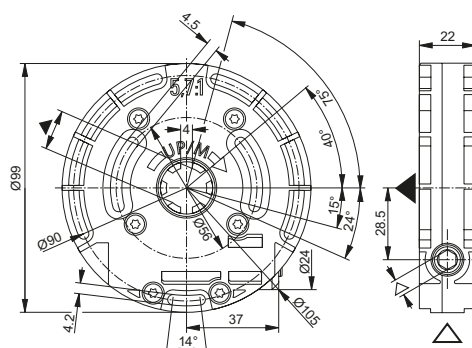
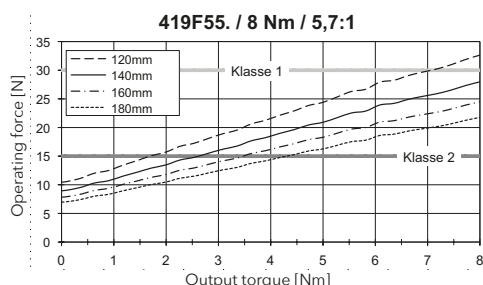

Part no.	End stop (AB)	Drive Δ	Output ∇
419F550	with AB	7 mm	16 mm
419F551	without AB	7 mm	16 mm
419F554	without AB	7 mm	10 mm
419F555	with AB	7 mm	10 mm
419F557	with AB	7 mm	8 mm
419F558	without AB	7 mm	8 mm

444F800 | Universal gearbox holder

Characteristics

- Height-adjustable: Oblong holes for stud bolts are available
- Suitable for gearboxes 419F..., 419F5..., 419F55..., 444F..., 446F..., 447F... and 456F...

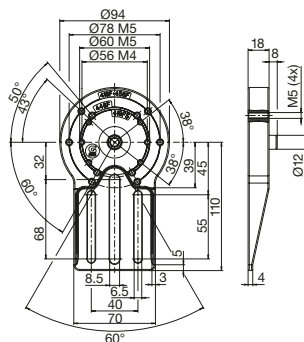

Part no.	
444F800	

419F901 | Freewheel

Characteristics

- For worm gear 419F... (only 5.33:1, max. 8 Nm) and 421F5.
- Prevents incorrect winding of the rolling shutter curtain
- One version for left or right installation

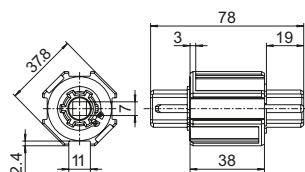

Part no.	Drive	Output	Comment
419F901	☙ 16 mm	● 37.8 mm	Freewheel left and right

419F9.. | Tube driver

Characteristics

■ For worm gearboxes 419F... and 421F5..

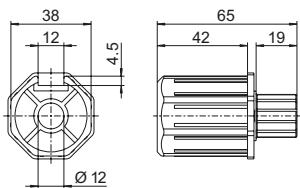

Part no.	Drive	Output
419F903	16 mm	38 mm

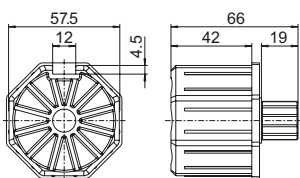

Part no.	Drive	Output
419F904	16 mm	57.5 mm

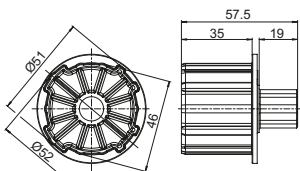

Part no.	Drive	Output
419F912	16 mm	ZF 54

Venetian blinds and external blinds

Rolling shutter

Textile sun protection

System components

421F5.. | Worm gear 5.33:1

Max. output torque	7.5 Nm
Gear reduction	5.33:1
Efficiency	0.40

Characteristics

- Without end stop (AB)
- Housing and worm wheel made of die-cast zinc
- Continuous internal profile on the drive and output

Note

- Coloured versions on request
- Versions with extension, mounted universal joint, plug-in crank system, zinc, or plastic eyelet or 8 mm square adapter on request

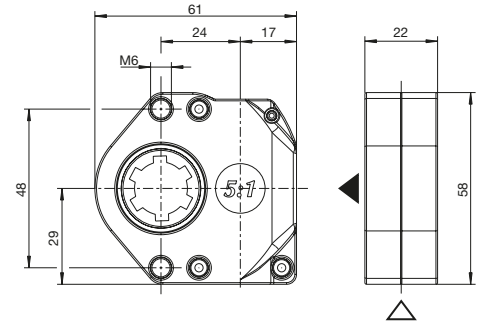
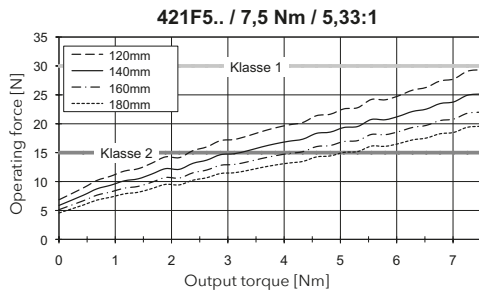

Part no.	Drive Δ	Output ∇
421F504	○ 6 mm	○ 13 mm
421F542	○ 7 mm	○ 13 mm
421F544	○ 6 mm	⬤ 16 mm
421F546	○ 7 mm	⬤ 16 mm

421F5.. | Worm gearbox 5.33:1 with end stop

Max. output torque	7.5 Nm
Gear reduction	5.33:1
Efficiency	0.40

Characteristics

- With end stop (AB)
- Housing made of die-cast zinc, worm wheel made of steel
- Continuous internal profile on the drive and output
- Available in three different housing designs

Note

- Coloured versions on request
- Versions with extension, mounted universal joint, plug-in crank system, zinc, or plastic eyelet or 8 mm square adapter on request

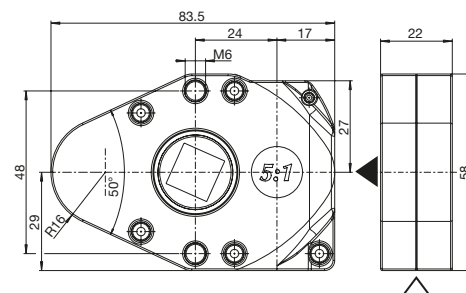
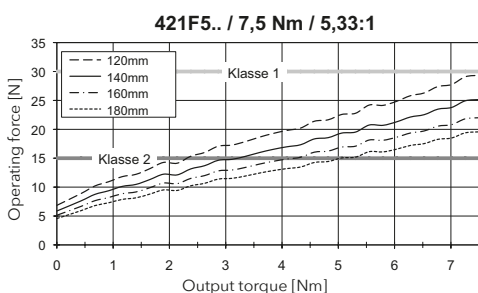
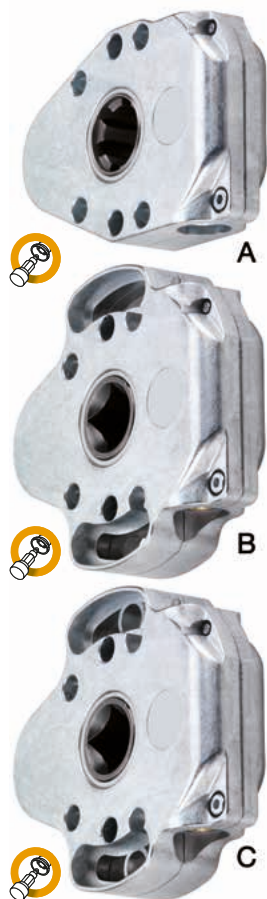

Housing design A (TK 48 mm)

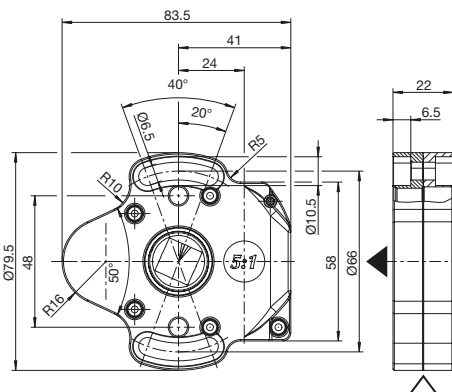

Housing design B (TK 66 mm)

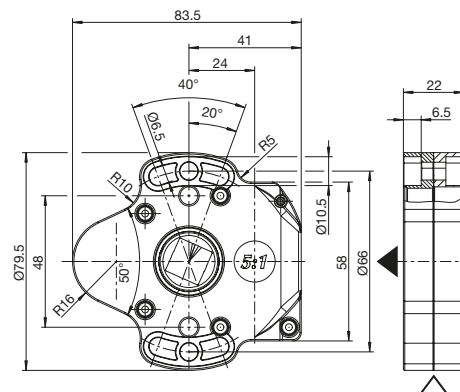

Housing design C (TK 66 mm with fixing)

Options for worm gearbox 5.33:1 with end stop	
Drive	○ 6 mm and ○ 7 mm, continuous interior profile
Output	○ or ○ 13 mm and ⚙ 16 mm, continuous interior profile
Pitch circle Ø	48 mm, 66 mm and 66 mm with fixation
Colours	blank or powder-coated

Housing design A

Part no.	Drive △	Output ▼
421F556	○ 6 mm	⚙ 16 mm
421F557	○ 7 mm	⚙ 16 mm
421F558	○ 7 mm	○ 13 mm
421F559	○ 6 mm	○ 13 mm

Housing design B

Part no.	Drive △	Output ▼
421F552	○ 6 mm	⚙ 16 mm
421F553	○ 7 mm	⚙ 16 mm
421F554	○ 7 mm	○ 13 mm

Housing design C

Part no.	Drive △	Output ▼
421F561	○ 6 mm	⚙ 16 mm
421F562	○ 7 mm	⚙ 16 mm
421F563	○ 7 mm	○ 13 mm
421F564	○ 6 mm	○ 13 mm

421F8.. | Worm gear 8:1

Max. output torque	20 Nm
Gear reduction	8:1
Efficiency	0.39

Characteristics

- Without end stop (AB)
- Zinc die-cast housing
- Worm and worm wheel made of steel
- Continuous internal profile on the drive and output
- Tested according to DIN EN 14201

Note

- Coloured versions on request
- Versions with extension, mounted universal joint, plug-in crank system, zinc, or plastic eyelet or 8 mm square adapter on request

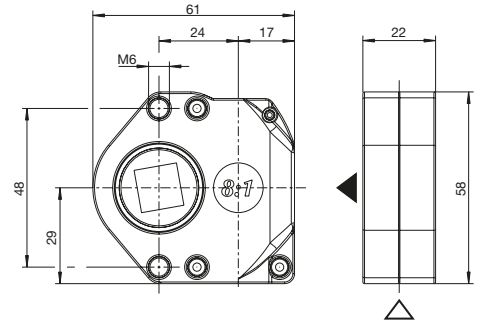
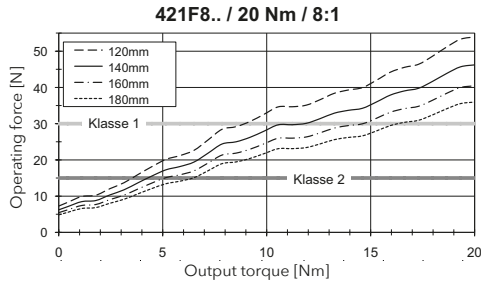

Part no.	Drive Δ	Output ∇
421F892	7 mm	10 mm
421F804	6 mm	13 mm
421F842	7 mm	13 mm

421F8.. | Worm gearbox 8:1 with end stop

Max. output torque	20 Nm
Gear reduction	8:1
Efficiency	0.39

Characteristics

- With end stop (AB)
- Housing made of die-cast zinc, worm wheel made of steel
- Continuous internal profile on the drive and output
- Available in three different housing designs
- Tested according to DIN EN 14201

Note

- Coloured versions on request
- Versions with extension, mounted universal joint, plug-in crank system, zinc, or plastic eyelet or 8 mm square adapter on request

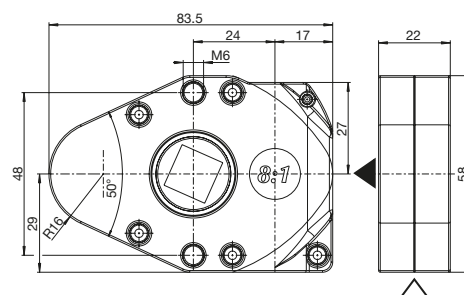
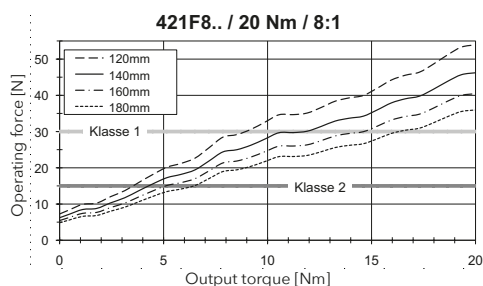
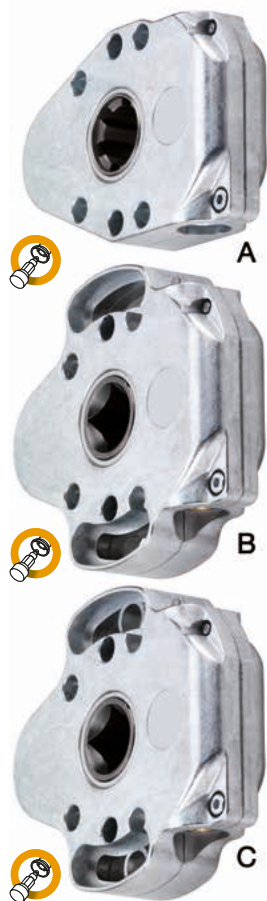

Housing design A (TK 48 mm)

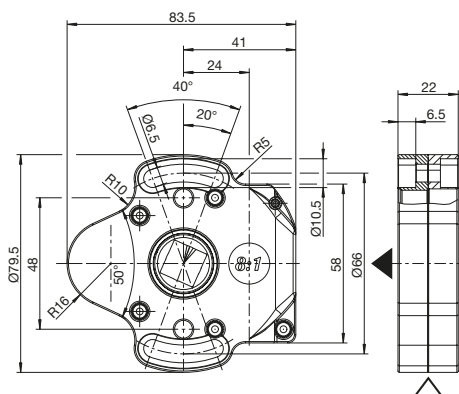

Housing design B (TK 66 mm)

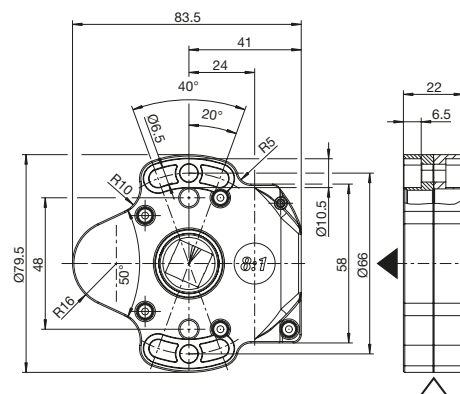

Housing design C (TK 66 mm with fixing)

Options for worm gearbox 8:1 with end stop

Drive	○ 6 mm and ○ 7 mm, continuous interior profile
Output	○ or ○ 13 mm and ⚙ 16 mm, continuous interior profile
Pitch circle Ø	48 mm, 66 mm and 66 mm with fixation
Colours	blank or powder-coated

Housing design A

Part no.	Drive △	Output ▼
421F855	○ 6 mm	⚙ 16 mm
421F856	○ 7 mm	⚙ 16 mm
421F857	○ 7 mm	○ 13 mm
421F861	○ 6 mm	○ 13 mm

Housing design B

Part no.	Drive △	Output ▼
421F851	○ 6 mm	⚙ 16 mm
421F853	○ 7 mm	○ 13 mm

Housing design C

Part no.	Drive △	Output ▼
421F862	○ 6 mm	⚙ 16 mm
421F863	○ 7 mm	⚙ 16 mm
421F864	○ 7 mm	○ 13 mm
421F865	○ 6 mm	○ 13 mm

Bevel gearboxes from the 444F..., 446F..., 456F... series

The GEIGER bevel gearboxes of the 444F..., 446F... and 456F... series have proven their worth millions of times in daily use. They have set standards, particularly with regard to operating comfort and safety. The high level of comfort of the gearboxes in particular is a decisive advantage for industry and trade.

Convenience due to low operating force and short cranking process

The main requirement for a rolling shutter drive is to be able to move hangings of any size with little effort and just a few turns of the crank. The GEIGER bevel gearboxes 444F.../446F.../456F... fulfil this ergonomic requirement.

The **unique brake spring with free wheel** – similar to a freewheel bike – switches the brake spring off when the hanging opens.

The efficiency can thereby be improved above 85%. Compared to gears without brake spring with freewheel the operation is here **smoother** and faster.

Incorrect operation is prevented by the integrated overrun clutch.

The GEIGER bevel gearboxes have an integrated overrun clutch. The rolling shutter curtain cannot be wound up in the wrong direction after reaching its lower end position. GEIGER bevel gearboxes of the 444F..., 446F... and 456F... series are subject to damage caused by incorrect winding. Regardless of whether the blind arrives at the bottom of the window sill or whether it hits an obstacle: the GEIGER overrun clutch triggers reliably. This provides security for your rolling shutter curtain and avoids unnecessary customer service visits on site.

Economical mounting thanks to integrated overrun clutch

GEIGER bevel gearboxes save you time when installing or replacing a gearbox. The inconvenience of setting an end stop is eliminated. The gearbox adapts to the conditions on site and automatically activates the overrun clutch in the lower end position.

Service life and operating safety thanks to proven GEIGER brake assembly

GEIGER bevel gearboxes are designed for more than 10,000 actuations. Depending on the degree of utilisation, this corresponds to a service life of well over 10 years.

Determining the gearbox design

If the rolling shutter is to be opened, the crank handle must be turned clockwise.

Please refer to the drawings on this page when ordering to ensure that the direction of rotation remains the same in different installation situations.

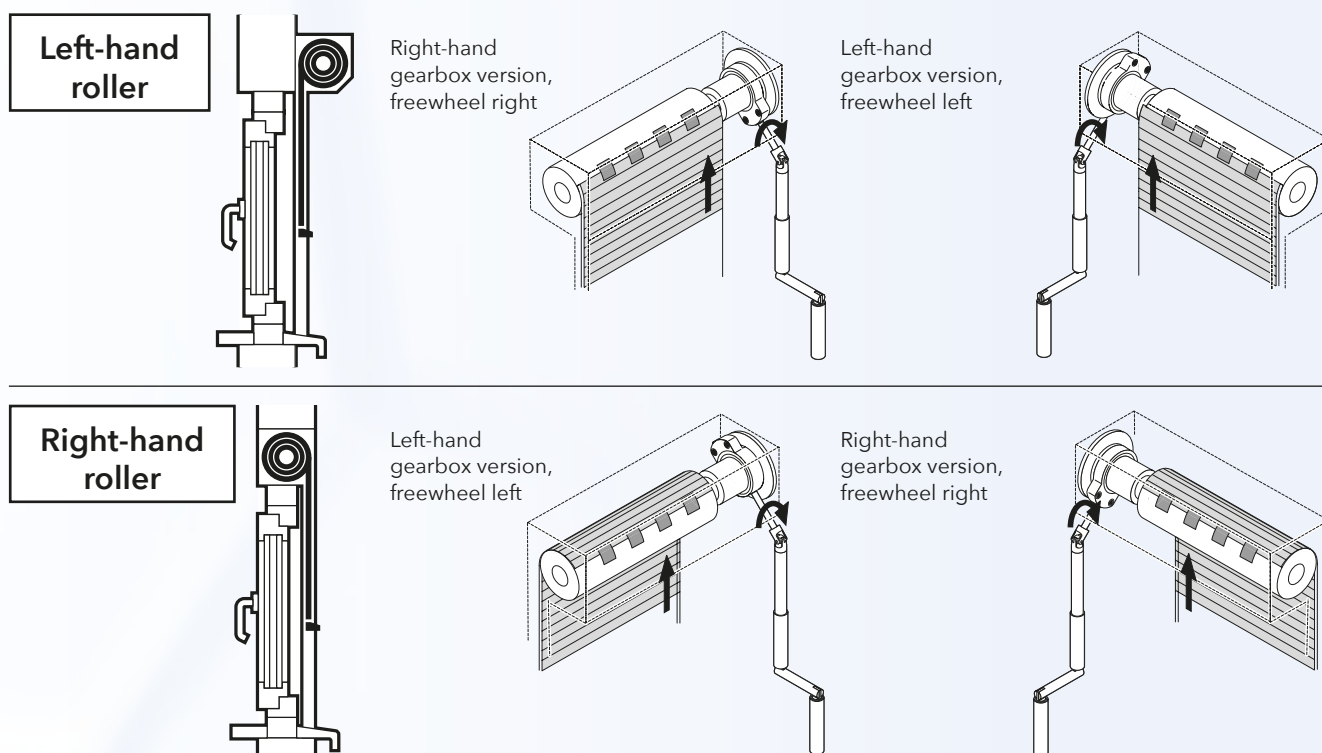

How do you distinguish between left and right gearbox versions?

With our bevel gearboxes 444F..., 446F... and 456F... it's really simple! Place the gearbox with the mounting side on the palm of your hand. If the coupling elements point to the left, it is a left-hand version. If the coupling elements point to the right, it is a right-hand version.

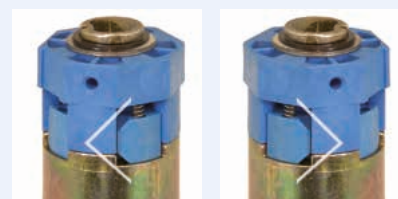

left-hand version

right-hand version

Reversible bevel gearboxes

We improve our products through continuous further development and thus make our customers' work easier. Thanks to an innovative solution, the bevel gearboxes in the 444F6.., 446F6.. and 456F6.. series are now suitable for left-hand and right-hand installation. No conversion, no tools, and no effort - just a simple flick of the wrist.

Customer benefits and product advantages

A simple changeover function for the overrun clutch has been integrated into the gearbox so that the gearbox can be installed on the left or right. As a tool-free system, it can be easily switched at any time.

As the patented changeover function is integrated in the gearbox, no components need to be dismantled or reconnected.

This means that no parts can be lost and the process is much easier and faster. Protection against unintentional switching is provided by a reliable locking mechanism with a marking on the switching mechanism.

The interior of the gearbox remains virtually unchanged - the technology that has been tried and tested millions of times remains the same!

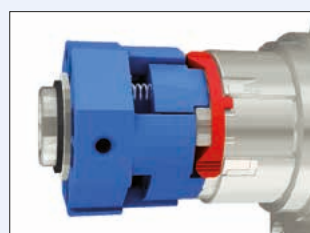

Turn the gearbox set for right-hand installation on the tube driver to the right ...



... until the overrun clutch disengages and the changeover mechanism is free.



Turn the changeover mechanism to the left to the stop ...



... and also turn the tube driver to the left until the overrun clutch engages.

Preparation of the side panel

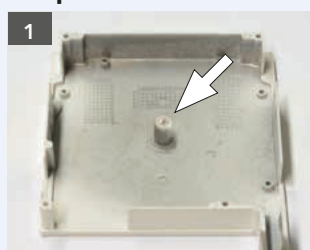

As the trunnion of the side panel is too high ...

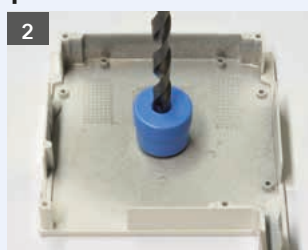

... it must be shortened to 8.5 mm.

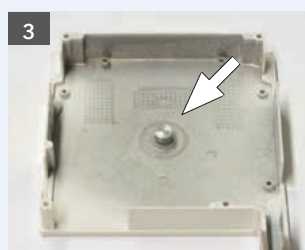

Once the trunnion has been shortened to the specified dimension, you can continue with the installation of the gearbox.

Installation of the bevel gearbox with quick-fit system



Fit the bevel gearbox with quick-fit system and clamping plate onto the shortened trunnion.



Roughly align the gearbox in the direction of the drive rod (45° or 90°)



Tighten the screw on the clamping plate (can be screwed on both sides) using a 3 mm Allen key.

Tightening torque: 3-4 Nm.



The final alignment to the drive rod is carried out on site **without** loosening the clamping screw.

444F7.. | Reversible bevel gearbox with quick assembly system 2:1

Max. output torque	8.5 Nm
Gear reduction	2:1
Efficiency	0.65

Characteristics

- Bevel gearbox 444F6... with special housing
- Tested according to DIN EN 14201
- Delivery status: Rotating direction right
- Quick assembly system: Tensioning the gear unit with the holding pin
- Reliable absorption of radial forces thanks to two additional bearing points
- No need to drill and countersink the cover cap
- Easy readjustment of the gearbox without tools
- Supplied as complete assembly kit with gear, rod bush, and locking mechanism

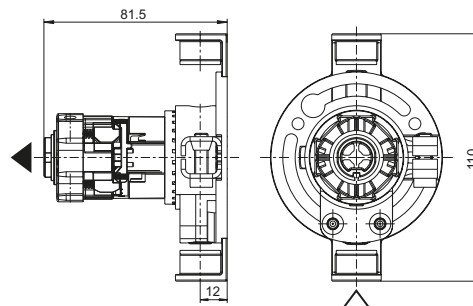
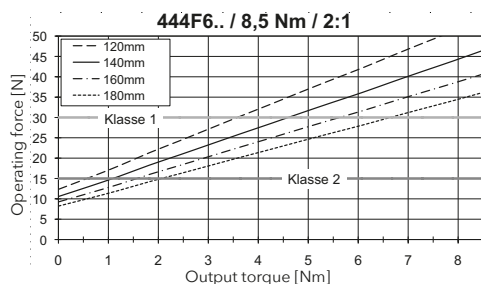

Part no.	End stop (AB)	Drive Δ	Output ∇
444F735	Overrun clutch left/right	\square 6 mm push-through	\bullet 38.0 mm

444F705 | Quick-assembly kit

Characteristics

- Can only be used with gearbox 444F7.. and 446F7..
- Including bearing bushes and clamping plate with screw

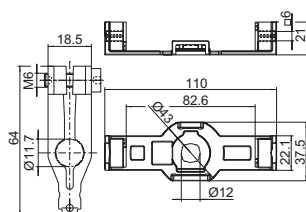

Part no.	
444F705	

446F7.. | Reversible bevel gearbox with quick assembly system 3:1

Max. output torque	9 Nm
Gear reduction	3:1
Efficiency	0.61

Characteristics

- Bevel gearbox 446F6... with special housing
- Tested according to DIN EN 14201
- Delivery status: Rotating direction right
- Quick assembly system: Tensioning the gear unit with the holding pin
- Reliable absorption of radial forces thanks to two additional bearing points
- No need to drill and countersink the cover cap
- Easy readjustment of the gearbox without tools
- Supplied as complete assembly kit with gear, rod bush, and locking mechanism

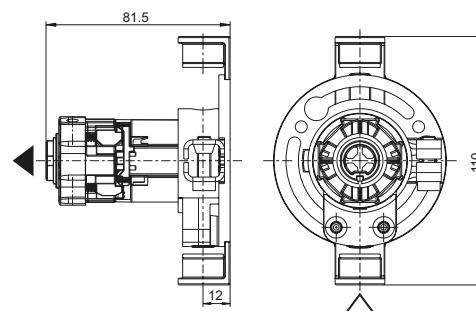
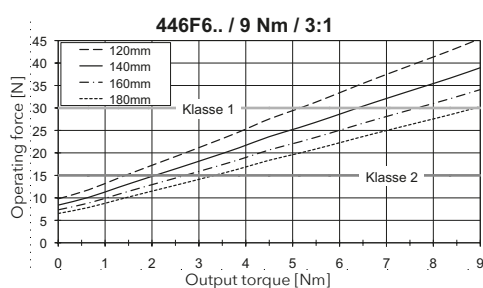
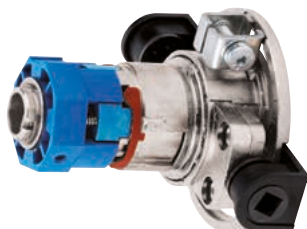

Part no.	End stop (AB)	Drive Δ	Output ∇
446F735	Overrun clutch left/right	\bigcirc 6 mm push-through	\bullet 38 mm

444F705 | Quick-assembly kit

Characteristics

- Can only be used with gearbox 444F7.. and 446F7..
- Including bearing bushes and clamping plate with screw

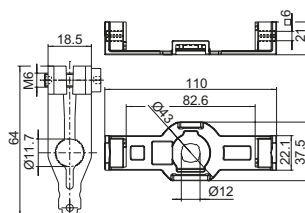

Part no.	Part no.
444F705	

456F... | Bevel gearbox 4:1

Max. output torque	12 Nm
Gear reduction	4:1
Efficiency	0.85

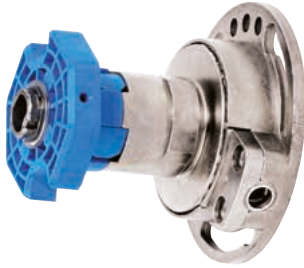

with brake spring freewheel

Characteristics

- Very easy operation due to brake spring freewheel
- Push-through interior profile on the drive
- Left-hand and right-hand version for the same direction of rotation with left-hand or right-hand installation
- Freewheel prevents incorrect winding of the rolling shutter curtain
- Tested according to DIN EN 14201

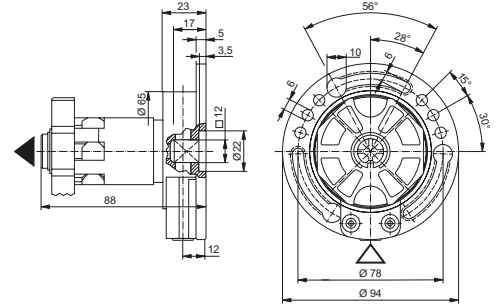
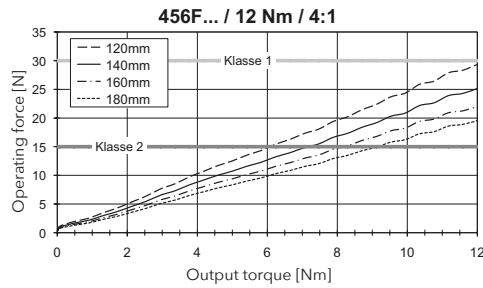

Part no.	End stop (AB)	Drive Δ	Output ∇
456F003	Freewheel left	<input type="radio"/> 6 mm push-through	<input checked="" type="radio"/> 36.7 mm
456F004	Freewheel right	<input type="radio"/> 6 mm push-through	<input checked="" type="radio"/> 36.7 mm
456F011	Freewheel left	<input type="radio"/> 6 mm push-through	<input checked="" type="radio"/> 57.5 mm
456F012	Freewheel right	<input type="radio"/> 6 mm push-through	<input checked="" type="radio"/> 57.5 mm
456F023	Freewheel left	<input type="radio"/> 6 mm push-through	<input checked="" type="radio"/> 38 mm
456F024	Freewheel right	<input type="radio"/> 6 mm push-through	<input checked="" type="radio"/> 38 mm

456F6.. | Reversible bevel gearbox 4:1

Max. output torque	12 Nm
Gear reduction	4:1
Efficiency	0.66



Characteristics

- Left-hand and right-hand version for the same direction of rotation with left-hand or right-hand installation
- Freewheel prevents incorrect winding of the rolling shutter curtain
- Tested according to DIN EN 14201
- Delivery status: Rotating direction right

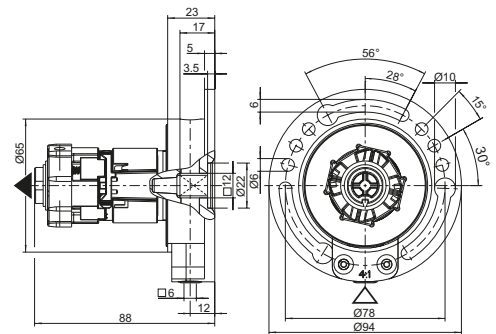
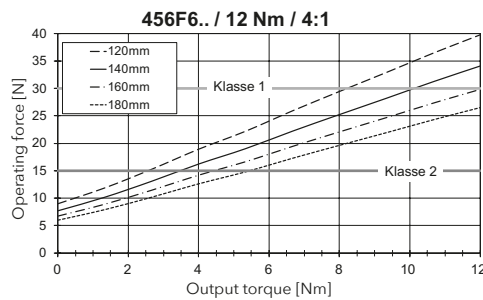

Options for bevel gearbox 446F6..

Drive	<input type="radio"/> 6 mm and <input type="radio"/> 6 mm push-through
Output	<input checked="" type="radio"/> 38 mm, 50 mm, 60 mm (see adapter)
Housing design	Standard
Pitch circle \varnothing	\varnothing 78 mm

Part no.	End stop (AB)	Drive Δ	Output ∇
456F603	Overrun clutch left/right	<input type="radio"/> 6 mm push-through	<input checked="" type="radio"/> 36.7 mm

444F800 | Universal gearbox holder

Characteristics

- Height-adjustable: Oblong holes for stud bolts are available
- Suitable for gearboxes 419F..., 419F5..., 419F55..., 444F..., 446F..., 447F... and 456F...

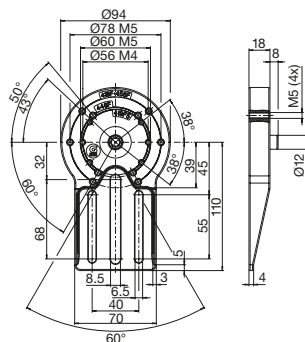

Part no.	
444F800	

444F90. | Adapter

Characteristics

- Made from high-strength plastic
- For adapting the gearbox output to the rolling shutter tube
- Suitable for gearboxes 444F..., 446F... and 456F... with 36.7 or 38 mm output profile

Note

- Please note the changed torque when using the tube adapter
- Recommendation: Secure adapter with pan head screw 4 x 16 mm

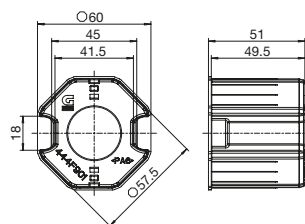

Part no.	Drive	Output
444F901	● 38 mm	● 60 mm

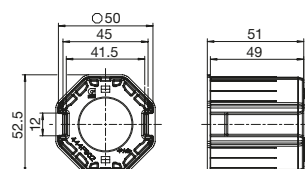

Part no.	Drive	Output
444F902	● 38 mm	● 50 mm

447F... | Bevel gearbox 3:1

Max. output torque	9 Nm
Gear reduction	3:1
Efficiency	0.65



Characteristics

- With end stop (AB) after max. 15 revolutions

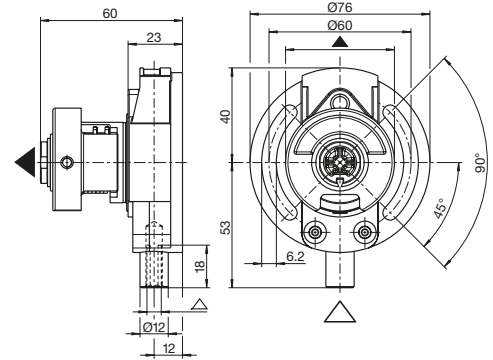
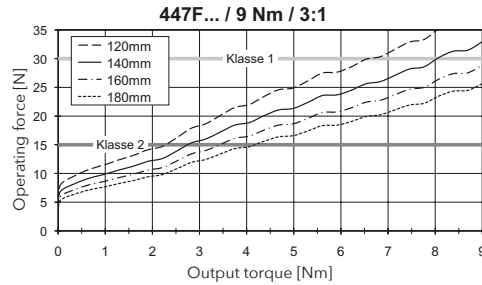

Part no.	End stop (AB)	Drive Δ	Output ∇
447F001	with AB	⊙ 6 mm	⊙ 46 mm
447F002	with AB	⊙ 6 mm	⊙ 46 mm
447F004	with AB	⊙ 6 mm	● 38 mm

444F800 | Universal gearbox holder

Characteristics

- Height-adjustable: Oblong holes for stud bolts are available
- Suitable for gearboxes 419F..., 419F5..., 419F55., 444F..., 446F..., 447F... and 456F...

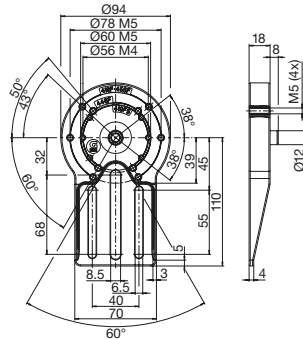

Part no.	
444F800	

460F... | Bevel gearbox 8:1

Max. output torque	22 Nm
Gear reduction	8:1
Efficiency	0.75

Characteristics

- Tube-enclosing bevel gearbox
- With end stop (AB) after max. 10 revolutions
- Matching adapter for 60 mm octagonal tube see 460F100
- See 460F12 for matching gearbox bracket.

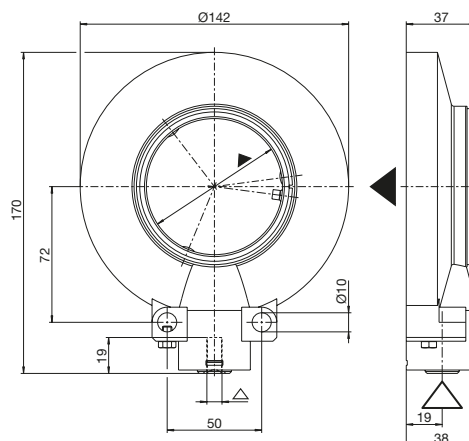
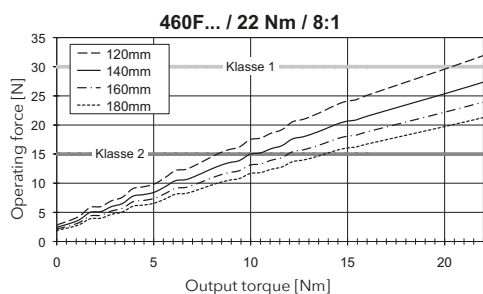

Part no.	Drive Δ	Output ∇
460F001	8 mm	Inner Ø 70 mm
460F002	8 mm	Inner Ø 60 mm

461F... | Bevel gearbox 5:1

Max. output torque	14 Nm
Gear reduction	5:1
Efficiency	0.77

Characteristics

- Tube-enclosing bevel gearbox
- With end stop (AB) after max. 13 revolutions
- Matching adapter for 60 mm octagonal tube see 460F100
- See 460F12 for matching gearbox bracket.

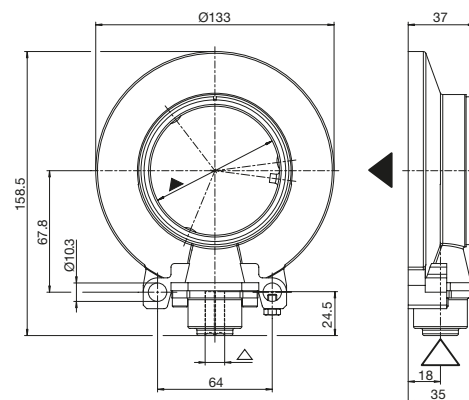
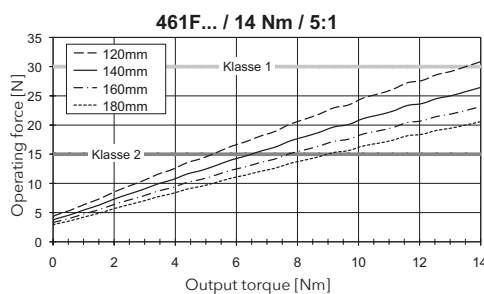

Part no.	Drive Δ	Output ∇
461F001	8 mm	Inner Ø 70 mm
461F002	8 mm	Inner Ø 60 mm

460F12. | Gearbox holder

Characteristics

- Made of steel
- Galvanised

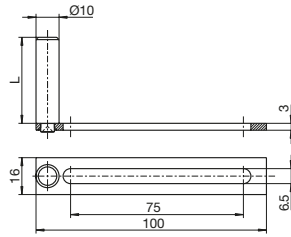

Part no.	Fixation
460F120	Ø 10 mm, L=60 mm
460F121	Ø 10 mm, L=80 mm

460F125 | Gearbox holder

Characteristics

- Made of steel
- Galvanised
- Adjustable from 143 mm to 334 mm

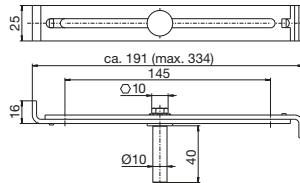

Part no.	
460F125	

460F11. | Axis

Characteristics

- Made of steel
- Galvanised

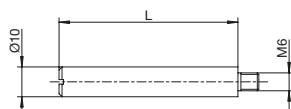

Part no.	Description
460F110	M6 Ø10, L=60 mm

460F100 | Adapter

Characteristics

- For octagonal tube 60 mm
- Made of plastic
- If the gearbox is floating, the adapter must be fixed in place!

Note

- Only for gearbox output Ø 70 mm, item no. 460F001 and 461F001

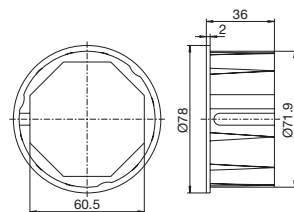

Part no.	
460F100	

462F... | Bevel gearbox 2.7:1

Max. output torque	6.0 Nm
Gear reduction	2.7:1
Efficiency	0.66

Characteristics

- Can be installed on the left and right with constant direction of rotation
- Only suitable for spherical plain bearing drive
- Coupling piece for use with an 8 mm square see 462F093
- Fixation by means of gear holder 462F070 or 462F071

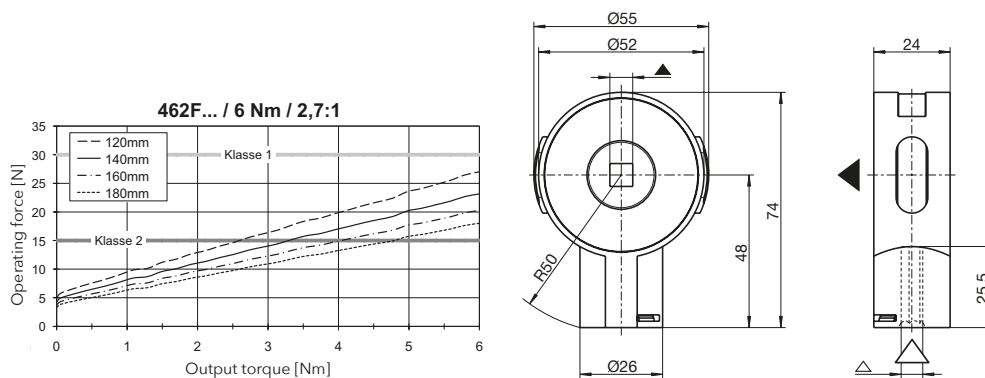

Part no.	End stop (AB)	Drive Δ	Output ∇
462F007	without AB	○ 6 mm	○ 12 mm
462F013	without AB	○ 6 mm	○ 10.2 mm
462F021	without AB	○ 6 mm	○ 14 mm

462F070 | Gearbox holder

Characteristics

- Made from high-strength plastic
- For side fixation
- Gearbox can be fitted on both sides

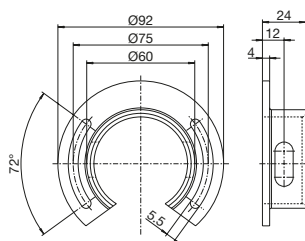

Part no.	
462F070	

462F093 | Coupling piece for gearbox 462F...

Characteristics

- Made of steel
- Galvanised

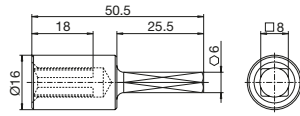
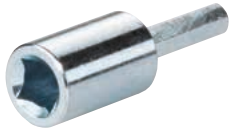

Part no.	Drive	Output
462F093	□ 8 mm	● 6 mm

462F080 | Adaptor for tube driver 462F085

Characteristics

- Made from die-cast zinc
- For tube driver 13 mm square, 462F085

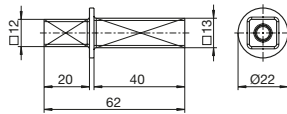

Part no.	Drive	Output
462F080	■ 12 mm	■ 13 mm

462F087 | Tube driver

Characteristics

- Made of plastic
- For octagonal tube
- With sliding steel pin

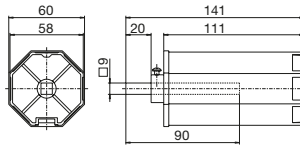

Part no.	Drive	Output
462F087	■ 9 mm	● 58 mm